

A Comparative Study of Photovoltaic Solar systems Performance between Numerical Simulation (Helioscope) and Real Systems

Alaa N. Abed^{1*}, Basim I. Wahab¹ & Hiba A. Hussein¹

(Type: Review Article). Received: 22nd Jun. 2025, Accepted: 12nd Sep. 2025, Published: 1st May. 2026,

DOI: <https://doi.org/10.35552/anu.jr.a.40.2.2608>

Abstract: In this research work, numerical simulation software has been utilized to predict the performance parameters of photovoltaic (PV) solar systems and compared with actual PV systems performance over a period of one year. The study aims to theoretically evaluate the performance of a PV system using Helioscope, and compare it with two actual PV systems and determine the accuracy of Helioscope software. The current simulated PV system is 5 kWp on-grid monocrystalline silicon (mono-Si) situated in Baghdad (33.33 °N and 44.44 °E). The tilt and azimuth angles of the PV solar modules are 20° and 0°, respectively. In this study, all performance parameters as well as atmospheric factors such as solar radiation and ambient temperature are taken into account. Helioscope validation is -4.44% to 0.85%. Helioscope accuracy will be confirmed by comparing it with an actual PV solar system. The Helioscope accuracy obtained in this study was 97.55%. The yearly AC energy outputs for the Helioscope and mono-Si system are 7819.3 kWh and 7891 kWh, respectively. The annual daily averages of final yield are 4.3 kWh/kWp/day and 4.5 kWh/kWp/day, respectively. The average yearly performance ratio & capacity factor are 72% & 74.7% and 17.85% & 17.7, respectively. The average yearly efficiencies are 10.37% and 11.33%, respectively. The annual global horizontal solar irradiation is 1968.6 kWh/m² and 1987.5 kWh/m², respectively. The average yearly overall losses are 1.757 kWh/kWp (29%) and 1.48 kWh/kWp (24.5%), respectively. The study showed that the Helioscope software is highly reliable and can be used to accurately predict the performance and energy output of PV solar systems. Furthermore, the CIGS solar module technology is the most suitable for the hot climate of Iraq.

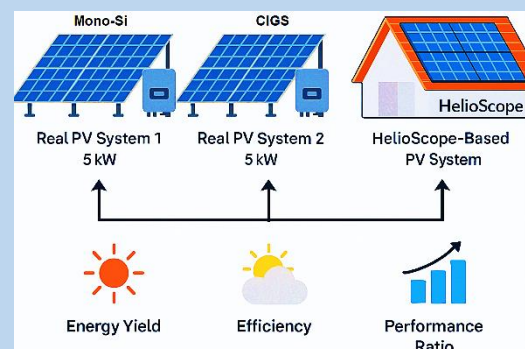

Keywords: Helioscope, PV systems, Atmosphere, Sustainability, Energy efficiency, Environment.

Introduction

Solar systems are used in many applications, such as electricity generation, heating and cooling systems, and water desalination, helping to build a more sustainable infrastructure. In the context of Iraq, particularly Baghdad, dependence on solar energy is a strategic choice due to the region's abundant solar radiation year-round [1]. Nonetheless, challenges persist about the performance of solar systems, including rising temperatures and significant dust accumulation. As a result, monitoring the performance of solar systems is essential for improving their efficiency and determining the most effective strategies for developing solar energy projects in Iraq [2]. As of the last quarter of the year 2024, the total capacity of installed solar systems globally has reached 2 terawatts, which is a significant development compared to previous years. Despite this rapid growth, 8 terawatts of solar capacity must be added by 2030 in order to meet the UN climate targets [3]. Investments in the PV solar systems sector are rising as solar module prices keep decreasing and efficiency rises, raising the potential of a

widespread transition to clean energy [4]. Simulation software is used to assess the performance of photovoltaic systems by analyzing efficiency and forecasting energy productivity depending on environmental and operational factors. The software includes PVsyst, PV*Sol, HOMER, SAM, Helioscope, RETScreen, Solar Pro, TRNSYS, and Polysun. These software help design, optimize solar systems, analyze economic feasibility, and assess the impact of weather factors on performance. This information contributes to making accurate and proactive decisions before implementing PV solar projects. [5,6]. Baghdad's energy system primarily relies on fossil-fueled thermal plants, emitting high levels of CO₂, NO, and SO₂. This contributes to air pollution and worsens respiratory and heart diseases among the population. Furthermore, Baghdad experiences frequent power outages due to insufficient supply compared to increasing demand, resulting in the widespread usage of private (civil) diesel generators in both residential and commercial sectors [7, 8]. Due to power challenges, reliance on

¹ Department of Atmospheric Science, College of Science, Mustansiriyah University, Baghdad-Iraq.

* Corresponding author: dr.alaa.atmsc@uomustansiriyah.edu.iq

ORCID iD: <https://orcid.org/0000-0002-9769-9430>

private diesel generators has progressively expanded from 2003 to the present, with around 12,500 private generators [9]. The use of PV systems is an important development in the agricultural sector [10]. Energy sources are diverse, but fossil fuels raise pollution and heat [11]. Many studies have been conducted on the use of simulation software to evaluate the PV solar systems performance. Okpe et al., evaluate the performance of a 407 kW solar plant system using PVsyst software. The study examined several significant variables, including geographical location, total solar panel area, inclination angle, inverter type & capacity, and other relevant factors. The results indicated that the plant produced 673.5 MWh per year with a performance rate of 83.3%. The investment in this solar plant was found to be profitable, with a return on investment of 165.8%. Additionally, the system contributed to a reduction of more than 6,000 tons of CO₂ annually [12]. Najib H. et al., studied ten photovoltaic system simulation programs to determine the most appropriate for performance analysis. A 1-megawatt plant is assessed by calculating the capacity factor and performance ratio, as well as highlighting defects in PV solar modules such as coated sheet discolouration, glass fragmentation, and dust deposition. The results indicated that HOME, SAM, RETScreen, and PVsyst are the best, with a need for development [13] Mahdi RO, Hacham W, studied the performance of a hypothetical 100 MW grid-connected photovoltaic (PV) system at Al-Khwarizmi College of Engineering at the University of Baghdad, using PVsyst 7.2 and Helioscope simulation software. The study aimed to evaluate energy production, shading effects, and orientation (tilt angle and azimuth). The findings showed that PVsyst produced 1,500.3 MWh while Helioscope produced 849.8 MWh annually [14]. Previous studies have not directly compared Helioscope's results with real solar systems using two different technologies, Mono-Si and Copper Indium Gallium Selenide (CIGS) PV

systems. This creates a scientific gap that requires evaluating Helioscope's accuracy in predicting the actual production of each technology.

In this study, three objectives are set in order to achieve the aim of this research work. The first objective is to employ Helioscope to conduct a theoretical performance assessment of a PV system that will be implemented in the future and to compare it to actual PV systems (mon-Si and CIGS PV systems). The second objective is to investigate the performance difference between the first generation (mono-Si) and second generation (CIGS) PV solar modules. The third objective is to determine the accuracy of the data generated by the Helioscope.

Methodology

Helioscope software description

The Helioscope is an essential tool for designing and evaluating the performance of the solar system by combining engineering analysis with climate data. The software displays a visual schematic of solar modules, allowing users to alter the tilt angle, azimuth angle, and spacing. Figure 1 shows (A) a PV solar system block circuit and (B) a rooftop PV solar system design simulation by Helioscope. Helioscope is distinguished by simulating the influence of shadows caused by buildings and obstructions and calculating potential losses. Figure 2 shows specifications of the simulated PV solar module (185 W). Figure 3 shows how to calculate the full annual energy production, fully analyze losses, and avoid shadows to optimize the design. The software also allows users to select the type of solar module, inverter, and losses. Helioscope was selected as one of the most widely used academic and engineering software for PV system design, combining high-resolution electrical and shading modeling and providing reliable outputs for performance validation against real PV systems.

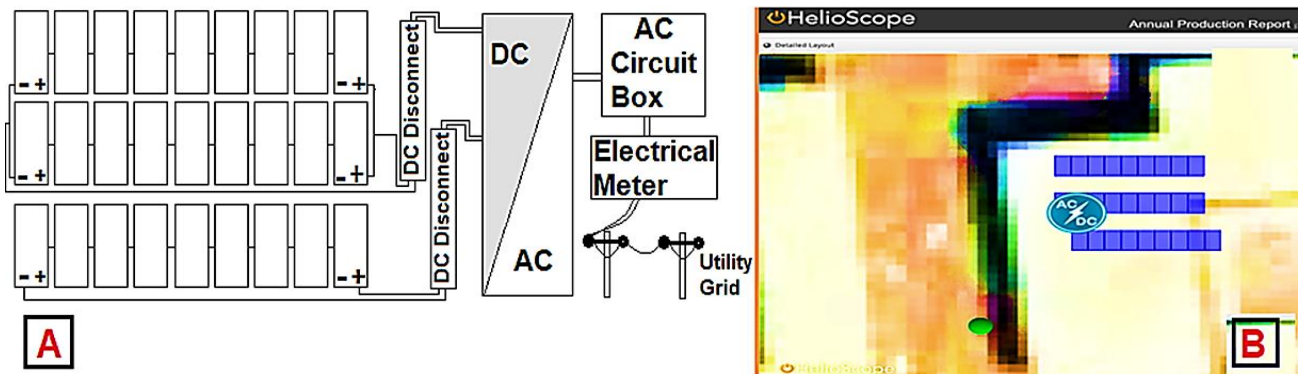

Figure (1): (A): PV solar system block circuit; (B): 5 kWp rooftop PV solar system design simulation by Helioscope.

| JKM-125M-72, 155W to 190W | | | | | | | | |
|---|--------------------------|----------|----------|----------|----------|----------|----------|----------|
| CELL TYPE | 125x125 MONO SOLAR CELL | | | | | | | |
| ITEM | JKM-155M | JKM-160M | JKM-165M | JKM-170M | JKM-175M | JKM-180M | JKM-185M | JKM-190M |
| MAX Power(Wp) | 155 | 160 | 165 | 170 | 175 | 180 | 185 | 190 |
| MAX Power Voltage(Vm) | 35±0.5 | 35±0.5 | 35±0.5 | 35.5±0.5 | 35.5±0.5 | 36±0.5 | 36±0.5 | 36±0.5 |
| MAX Power Current(I _m) | 4.43±0.5 | 4.57±0.5 | 4.71±0.5 | 4.79±0.5 | 4.93±0.5 | 5±0.5 | 5.14±0.5 | 5.28±0.5 |
| Open circuit Voltage (V _{oc}) | 42±0.5 | 42±0.5 | 42±0.5 | 42.6±0.5 | 42.6±0.5 | 43.2±0.5 | 43.2±0.5 | 43.2±0.5 |
| Short circuit Current (I _{sc}) | 4.96±0.5 | 5.12±0.5 | 5.28±0.5 | 5.36±0.5 | 5.52±0.5 | 5.6±0.5 | 5.76±0.5 | 5.91±0.5 |
| MAX Series Fuse | 10A | | | | | | | |
| No of Diode | 3 | | | | | | | |
| Number of cells | 72 (6x12) | | | | | | | |
| MAX system voltage | 600 (UL) /1000(TUV, VDE) | | | | | | | |
| Temperature coefficients of P _m | -0.37%/°C | | | | | | | |
| Temperature coefficients of V _{oc} | -0.34%/°C | | | | | | | |
| Temperature coefficients of I _{sc} | 0.09%/°C | | | | | | | |
| Nominal Operating Cell Temperature | 50±2°C | | | | | | | |
| Output tolerance | ±3% | | | | | | | |

Figure (2): Specifications of simulated PV solar module (JKM-185M (185 W)).

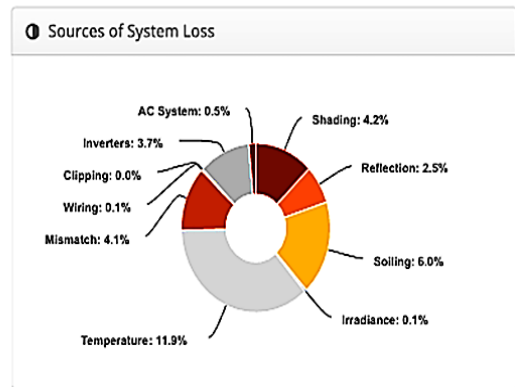
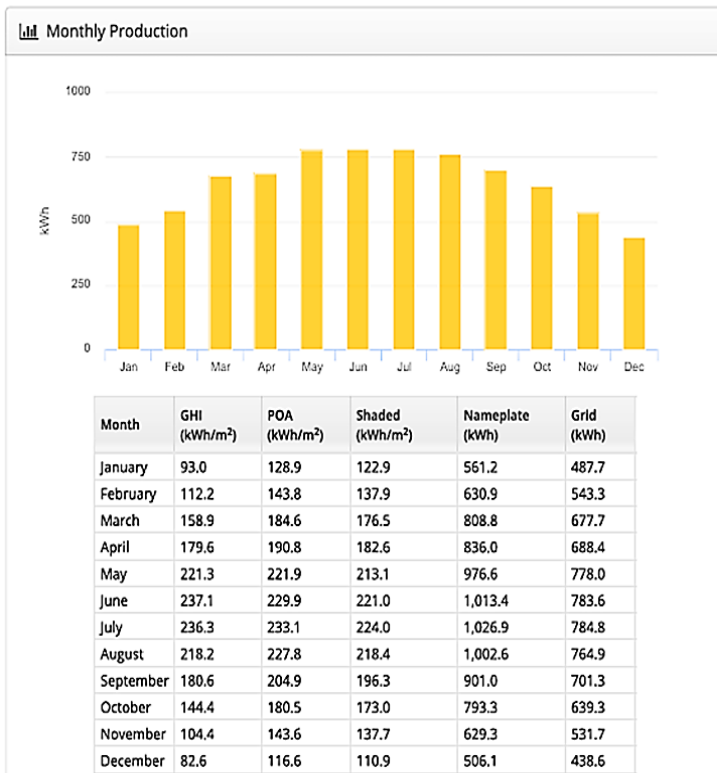

Figure (3): Production and losses details.

This simulation software (Helioscope) provides only three performance parameters: energy output, losses, and performance ratio. The authors calculated important performance parameters, such as efficiency, system yield, and capacity factor, as mentioned in section (3). The performance parameters calculated by this software are only one value, representing an annual average instead of a monthly detail. The authors expanded this program's analysis to include a full monthly analysis. Figure 4 displays the simulator version, system metric, and project location.

Figure 5 displays all the technical information used in the simulation process for the PV solar modules: nameplate, model, number of PV modules, operating temperature, tilt angle, and orientation angle. As well as the PV system in general: inverter specification, PV module wiring, frame size, and intrarow spacing. The simulated PV system data (Helioscope data) will be presented in Appendix-A, while the actual PV system data are found in References 25 and 26.

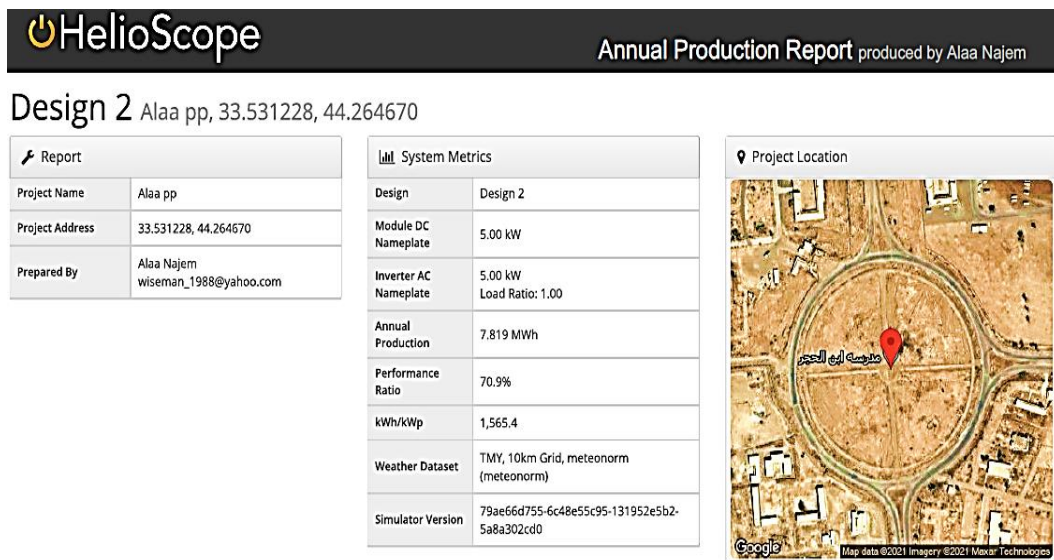

Figure (4): Simulator version, system metric and project location.

| ⚡ Annual Production | | | |
|----------------------------------|-------------------------------------|----------------|--------------|
| | Description | Output | % Delta |
| Irradiance (kWh/m ²) | Annual Global Horizontal Irradiance | 1,968.6 | |
| | POA Irradiance | 2,206.4 | 12.1% |
| | Shaded Irradiance | 2,114.2 | -4.2% |
| | Irradiance after Reflection | 2,062.2 | -2.5% |
| | Irradiance after Soiling | 1,938.5 | -6.0% |
| | Total Collector Irradiance | 1,939.0 | 0.0% |
| Energy (kWh) | Nameplate | 9,686.0 | |
| | Output at Irradiance Levels | 9,672.6 | -0.1% |
| | Output at Cell Temperature Derate | 8,520.6 | -11.9% |
| | Output After Mismatch | 8,169.0 | -4.1% |
| | Optimal DC Output | 8,161.7 | -0.1% |
| | Constrained DC Output | 8,161.0 | 0.0% |
| | Inverter Output | 7,858.6 | -3.7% |
| | Energy to Grid | 7,819.3 | -0.5% |
| Temperature Metrics | | | |
| | Avg. Operating Ambient Temp | | 25.7 °C |
| | Avg. Operating Cell Temp | | 44.3 °C |
| Simulation Metrics | | | |
| | Operating Hours | | 4547 |
| | Solved Hours | | 4547 |

| 📄 System Metrics | |
|-----------------------|---|
| Design | Design 2 |
| Module DC Nameplate | 5.00 kW |
| Inverter AC Nameplate | 5.00 kW Load Ratio: 1.00 |
| Annual Production | 7.819 MWh |
| Performance Ratio | 70.9% |
| kWh/kWp | 1,565.4 |
| Weather Dataset | TMY, 10km Grid, meteonorm (meteonorm) |
| Simulator Version | 79ae66d755-6c48e55c95-131952e5b2-5a8a302cd0 |

| 🔧 Components | | |
|--------------|------------------------------|--------------|
| Component | Name | Count |
| Inverters | Sunny Boy 5.0-1AV-41 (SMA) | 1 (5.00 kW) |
| Strings | 10 AWG (Copper) | 3 (89.8 ft) |
| Module | Jinko Solar, JKM-185M (185W) | 27 (5.00 kW) |

| 🔌 Wiring Zones | | | |
|----------------|----------------|-------------|--------------------|
| Description | Combiner Poles | String Size | Stringing Strategy |
| Wiring Zone | - | 6-12 | Along Racking |

| 📐 Field Segments | | | | | | | | | |
|------------------|------------|---------------------|------|---------|------------------|------------|--------|---------|---------|
| Description | Racking | Orientation | Tilt | Azimuth | Intrarow Spacing | Frame Size | Frames | Modules | Power |
| Field Segment 1 | Fixed Tilt | Portrait (Vertical) | 20° | 0° | 4.0 ft | 1x1 | 27 | 27 | 5.00 kW |

Figure (5): Helioscope technical details.

Preparing for a PV solar system performance analysis

The performance evaluation study in this research comprises two major parts: The first part is to conduct a theoretical performance evaluation of the PV solar system and compare it to actual PV solar systems installed at the same location. The second part is to compare the differences between first-generation (mono-Si) and second-generation (CIGS) PV solar modules. Performance parameters include energy output (DC energy and AC energy), system yields (reference yield, array yield, and final yield), losses (array losses, system losses, and overall losses), efficiencies (array efficiency, system efficiency, and inverter efficiency), capacity factor, and performance ratio.

Energy output analysis

A photovoltaic solar system produces two types of energy: DC energy (array energy) and AC energy. DC energy is produced by solar modules, while AC energy is produced after the direct energy leaves the inverter. The difference between DC energy and AC energy is the inverter losses. DC energy loses a very small amount of energy during conversion from DC energy to AC energy. The energy produced can be calculated on an hourly ($E_{AC,h}$), daily ($E_{AC,d}$) monthly ($E_{AC,m}$) and annually, as in the following equations: [15, 16].

$$E_{AC,h} = \sum_{t=1}^{60} E_{AC,t} \quad (1)$$

$$E_{AC,d} = \sum_{h=1}^{24} E_{AC,h} \quad (2)$$

$$E_{AC,m} = \sum_{d=1}^n E_{AC,d} \quad (3)$$

System yields analysis

Yield is one of the important performance parameters, which includes three types: array yield (YA), final yield (YF) and reference yield (YR). Array yield is expressed in terms of DC energy, whereas final yield is expressed in terms of AC energy. YA and YF represent the number of hours the PV system operates at its rated capacity (without losses). YA and YF are calculated by dividing the actual energy produced over a

specified time period by the PV system's rated capacity. While YR represents the number of hours the PV array (modules) receives solar radiation of 1 Kw/m2. YR is also called peak sun hour. YA, YF and YR are given as follows [17, 18].

$$Y_A = (E_{DC}/P_{Rated})(kWh/kWp) \quad (4)$$

$$Y_F = (E_{AC}/P_{Rated})(kWh/kWp) \quad (5)$$

$$Y_R = (H_t/H_R)(kWh/kWp) \quad (6)$$

Where: EDC, EAC, Ht and HR are the DC energy, AC energy, in-plane solar irradiation, and reference solar irradiance (1 kW), respectively.

Efficiency analysis

Conversion efficiency in photovoltaic systems is divided into three sets: array efficiency (η_{PV}), system efficiency (η_{syst}), and inverter efficiency (η_{INV}). The array efficiency and system efficiency are given as follows [19, 20, 21].

$$\eta_{PV} = (E_{AC}/H_t * A_m) * 100\% \quad (7)$$

$$\eta_{syst} = (E_{AC}/H_t * A_m) * 100\% \quad (8)$$

$$\eta_{INV} = (E_{AC}/E_{DC}) * 100\% \quad (9)$$

Where: Am is the array area (area of PV solar modules).

Losses analysis

Losses in PV systems are divided into three classes: overall losses (LO), system losses (LS) and array losses (LA). Array losses refer to the losses that occur when a PV module is unable to convert solar radiation into electrical energy at its rated efficiency (η_{Rated}). LA also appears when the reference irradiance and the actual irradiance are different because the PV modules' capacity is determined using the reference irradiance of 1 kW. While LS represents an inverter's inability to convert all DC energy to AC energy (inverter losses). LO is LA plus LS. LA, LS, and LO are given as follows [22].

$$L_A = Y_R - Y_A (kWh/kWp) \quad (10)$$

$$L_S = Y_A - Y_F (kWh/kWp) \quad (11)$$

$$L_O = L_A + L_S (kWh/kWp) \quad (12)$$

Performance Ratio (PR) analysis

PR is one of the most important standards used to evaluate the performance of solar PV systems. It expresses how close the actual PV system performance is to the ideal performance [23]. It represents the ratio of the actual energy produced by the system to the theoretical energy that could be produced under ideal conditions. It is calculated using the following equation [24, 25].

$$PR = E_{AC}/H_t * A_m * \eta_{Rated} (\%) \quad (13)$$

Where: η_{rated} is the rated (nominal) efficiency of the PV solar modules.

PR is also stated in terms of yields as follows:

$$PR = Y_F/Y_R * 100 (\%) \quad (14)$$

Capacity factor (CF) analysis

Capacity factor is a measure of how efficiently a photovoltaic (PV) system operates over a given period of time compared to its theoretical maximum output. It is expressed as a percentage of time and is one of the most significant performance indicators used to compare PV systems. It is calculated using the following equation [26, 27].

$$CF = E_{AC}/(P_{Rated} * 8760) (\%) \quad (15)$$

Where: P_{Rated} is the rated power capacity of the PV solar system.

Results and discussion

The validation range for Helioscope's current results is - 4.44% to 0.85% (or $\pm 2.45\%$ as average). This calculated range is very close to the validation ranges for PV*Sol, SAM, and

PVsyst published in the NREL report, which range from -5.5% to 1.4%, -5.0% to 4.1%, and -1.7% to 5.5%, respectively [28]. The above results indicate that Helioscope has the lowest error rate among the mentioned programs. In this study, only simulated solar system data will be drawn, (not real PV system data), to ensure that the figures are clear and intelligible. These systems will be compared through contextual explanations and tables.

Figure 6 illustrates an extensive analysis of the PV solar system simulation results, including energy output (AC and DC energy) and solar irradiation. Solar radiation is direct related to output (electricity). The output (AC and DC) gradually increases from January through June, peaking, before declining until December. The most significant aspect of this section is determining the degree of convergence between the simulated PV system and actual PV system findings in order to understand the simulated PV system's behavior. It should be noted that there is a high degree of convergence between the simulated system and the Mono-Si PV system in the summer. However, there is some divergence in the winter, because the Helioscope uses a meteorological database (metenorm) with a specific accuracy (not full accuracy), and the simulated PV system tilt angle is 20o, which makes production ideal in the summer, autumn, and spring while it decreases slightly in the winter. This tilt angle is necessary when electricity is needed more in the summer, autumn, and spring than in the winter. In terms of annual production, Table 1 reveals a strong convergence between the simulated PV system and the mono-silicon PV system, indicating that the simulated PV system (software) is very close to reality [29, 30]. The CIGS PV system is somewhat different from simulated PV system, because the CIGS technology has better physical characteristics compared to mono-Si PV modules.

Table (1): Production comparison between actual and simulated systems.

| | Simulated PV system | Mono-Si PV system (actual system) [29] | CIGS PV system (actual system) [30] |
|------------------------|---------------------|--|-------------------------------------|
| Annual energy output | 7819.3 kWh/year | 7891 kWh/year | 8792 kWh/year |
| Maximum value (summer) | 784.8 kWh | 756 kWh | 876.159 kWh |
| Minimum value (winter) | 438.6 kWh | 532.97 kWh | 567.9 kWh |

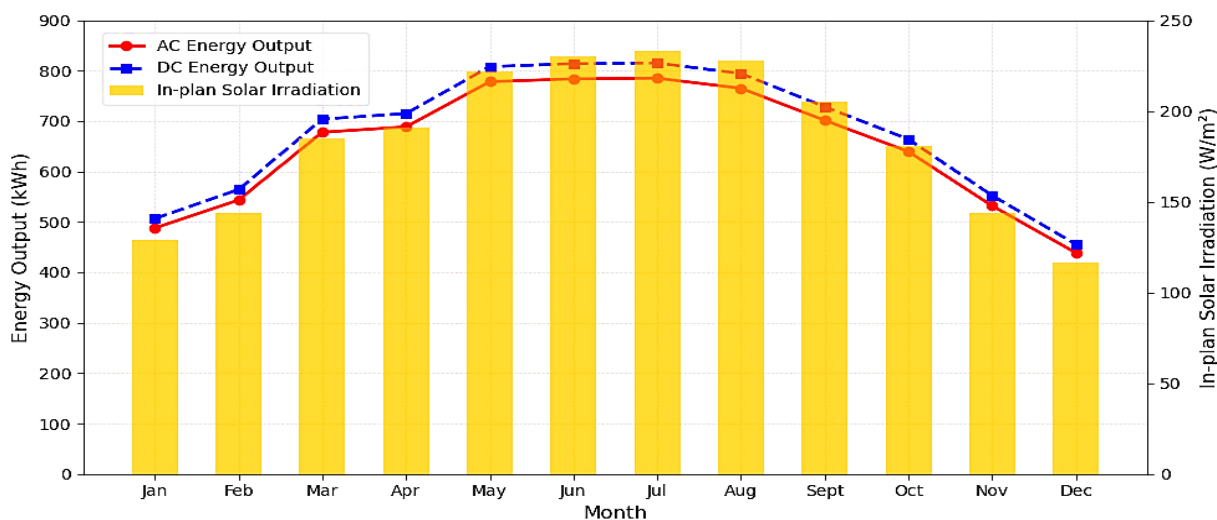

Figure (6): Solar irradiation, AC and DC energy output..

Figure 7 illustrates the three types of simulated system daily yields. It should be noted that all yields reach their maximum values in the summer, as the reference yield, final yield, and array yield follow the same pattern. The yearly average daily final yield and reference yield are 4.3 kWh/kWp and 6 kWh/kWp, respectively. This means that a monocrystalline silicon PV system in Baghdad operates for only 4.3 hours and receives only 6 hours of solar radiation [29]. The maximum final yield and reference yield values in May, June, July and August are 5.2

kWh/kW and 7.4 kWh/kW, respectively. While the maximum values in January, February, November and December are 3.1 kWh/kW and 4 kWh/kW, respectively. Table 2 represents the yield comparison between actual and simulated systems. Table 2 shows a strong convergence between the simulated PV system and the actual mono-Si PV system, with a significant divergence from the CIGS PV system, indicating that the simulated system is close to reality [29, 30].

Table (2): Final yield comparison between actual and simulated systems.

| | Simulated PV system | Mono-Si PV system (actual system) [29] | CIGS PV system (actual system) [30] |
|----------------------------|---------------------|--|-------------------------------------|
| Annual average final yield | 4.3 kWh/kWp | 4.5 kWh/kWp | 4.87 kWh/kWp |
| Maximum value (summer) | 5.2 kWh/kWp | 5.3 kWh/kWp | 5.97 (or 6) kWh/kWp |
| Minimum value (winter) | 3.1 kWh/kWp | 3.58 kWh/kWp | 3.7 kWh/kWp |

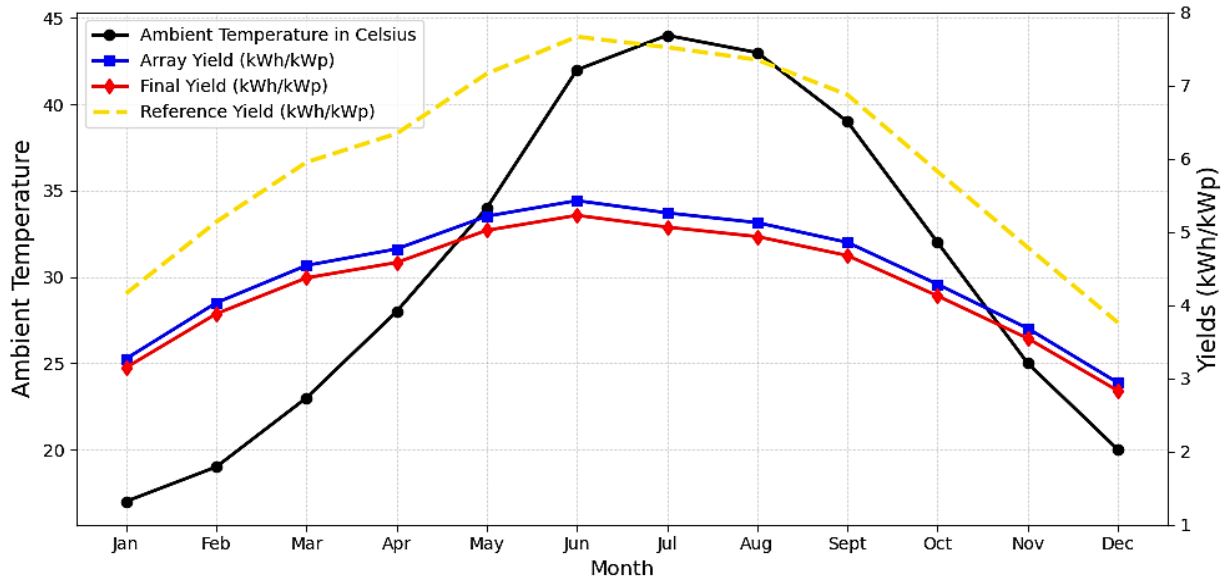

Figure (7): Ambient temperature, array, final and reference yields.

Figure 8 illustrates the array and system efficiency of the simulated system. Figure 8 depicts the inverse relationship between ambient temperature and efficiency. System efficiency includes inverter losses, making it lower than array efficiency. The maximum and minimum efficiency values occur in winter and summer, respectively. Efficiency losses can be used to compare the simulated and real systems due to their different

efficiencies. PV system efficiency losses are calculated based on how much actual efficiency differs from nominal. For example, the mono-Si nominal efficiency is 16%, whereas the minimum value is 10.08%, resulting in an efficiency loss of 5.92% [29]. Table 3 clearly shows that the mono-Si PV system has the highest losses, being close to the simulated PV system but far from the CIGS PV system [29, 30].

Table (3): Efficiency comparison between actual and simulated systems.

| | Simulated PV system | Mono-Si PV system (actual system) [29] | CIGS PV system (actual system) [30] |
|-------------------------|---------------------|--|-------------------------------------|
| Nominal efficiency | 14.5% | 16% | 15.3% |
| Maximum losses (summer) | 4.76% | 5.92% | 3.62% |
| Minimum losses (winter) | 3.5% | 3.45% | 2.51% |

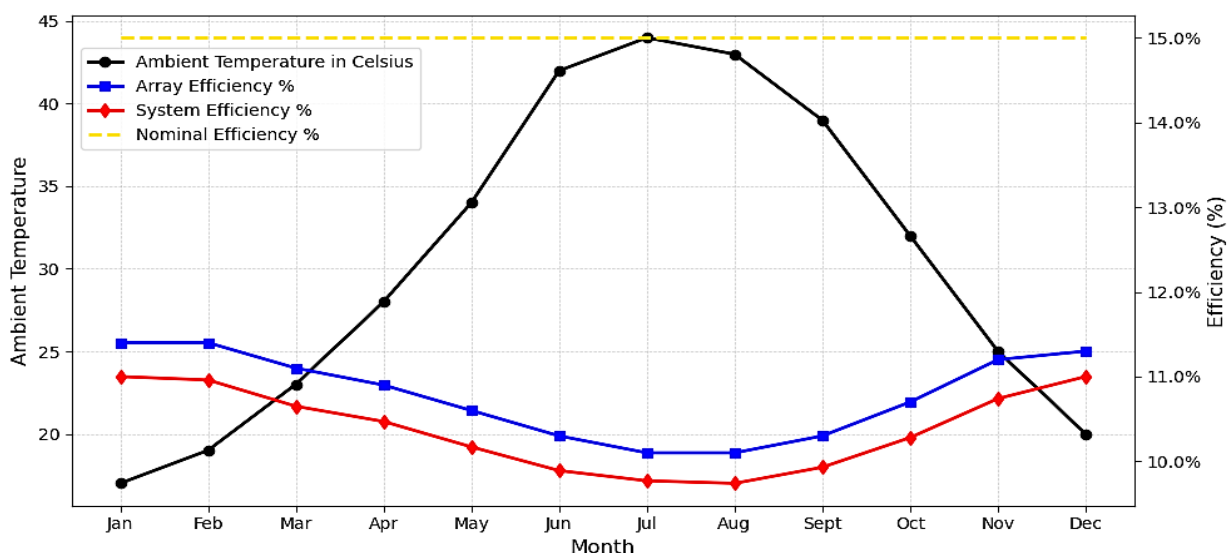

Figure (8): Ambient temperature and efficiency.

Figure 9 depicts the array, system, and total losses. Figure 9 illustrates the direct relationship between ambient temperature and PV solar system losses. The system losses are lowest as they just comprise conversion losses (or inverter losses). Figure 9 and Table 4 illustrate that the highest and lowest overall losses occur during the summer and winter, respectively. In this section,

the Helioscope losses report will be discussed. Figure 10 depicts the losses report, which represents the losses (in %) for the month with the highest losses (July). The total losses value in this report about 33% (2.43 kWh/kWp per day). The losses in this report total 33% (2.43 kWh/kWp each day). This value (33%) appears exactly in July and almost in June, August, and

September, making the PR 67%-68%. The value of 33% exactly matches the loss result for a mono-Si PV system. The value of 2.43 kWh/kWp/day indicates that the PV solar system operates only 5 hours out of 7.4 hours (2.4 hours are lost), where 7.4 is the reference yield (7.4 kWh/kWp/day). The annual average

overall loss is about 1.757 kWh/kWp (29%). Table 5 clearly demonstrates that the losses of the mono-Si PV system are close to those of the simulated PV system but far from those of the CIGS PV system in the summer. While the losses of all PV solar systems converge in winter [29, 30].

Table (4): Losses comparison between actual and simulated systems.

| | Simulated PV system | Mono-Si PV system (actual system) [29] | CIGS PV system (actual system) [30] |
|---------------------------------|-------------------------------|--|-------------------------------------|
| Annual average losses | 1.75 kWh/kWp/day (1.75 hour) | 1.5 kWh/kWp/day (1.5 hour) | 1.2 kWh/kWp/day (1.2 hour) |
| Maximum overall losses (summer) | 2.43 kWh/kWp/day (2.43 hours) | 2.41 kWh/kWp/day (2.4 hours) | 1.74 kWh/kWp/day (1.74 hour) |
| Minimum overall losses (winter) | 0.93 kWh/kWp/day (0.93 hour) | 0.71 kWh/kWp/day (0.71 hour) | 0.698 kWh/kWp/day (0.698 hour) |

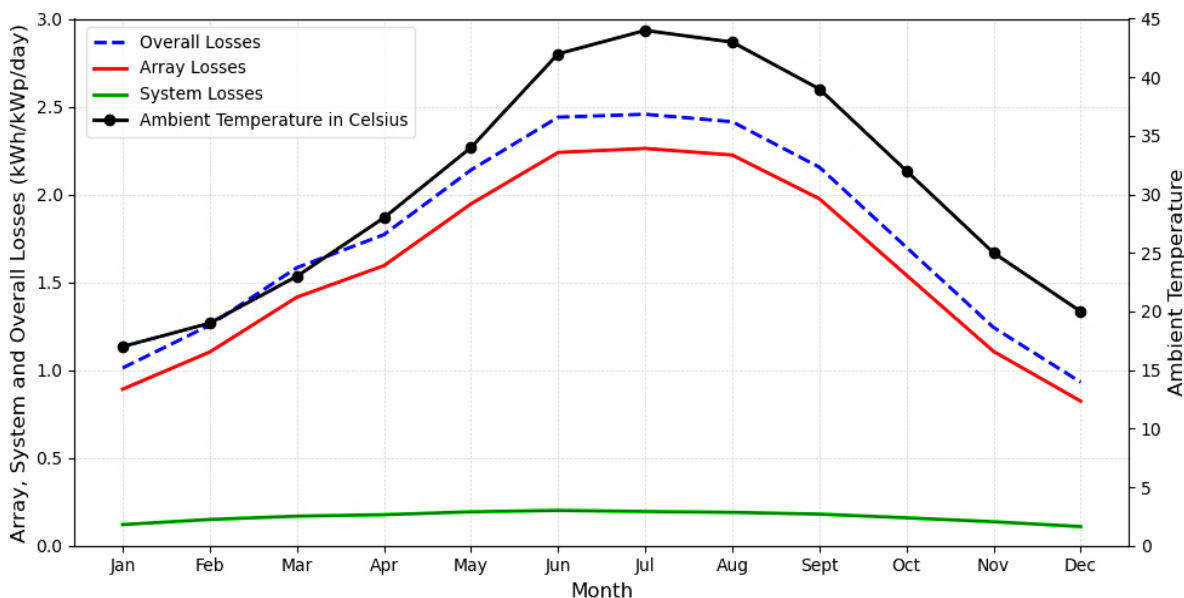

Figure (9): Ambient temperature and losses.

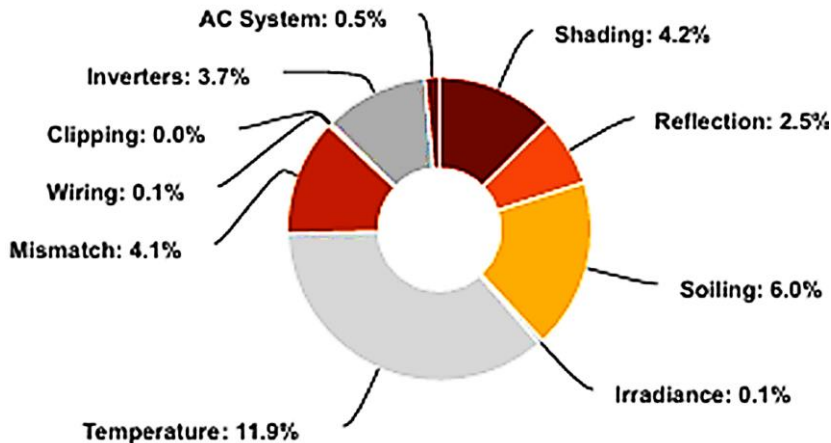

Figure (10): Helioscope losses report.

Figure 11 demonstrates the performance ratio and capacity factor. The PR displays all the losses that the solar PV system experiences. The most significant atmospheric element influencing the PR and CF is ambient temperature, in addition to soiling. Annual average PR is 71.5%. PR peaks at 76% in January/December (winter) and drops to 67% in June/July/August (summer). Regarding CF, it peaks at about 21% in May, June, July, and August thanks to the appropriate tilt angle and day length, leading to increased exposure to solar radiation. The yearly average CF is 17.85%, which is equivalent to 65.1 days per year, indicating that the PV system produces energy at full capacity for about 62.1 days. CF represents the percentage of time the PV solar system operates at its rated capacity (17.85% of the time per year). CF depends primarily on solar radiation intensity, tilt angle, weather conditions such as

clouds, fog, dust, system design, component efficiency, and periodic maintenance. PR is a critical standard for comparing PV systems irrespective of tilt angle, orientation angle, solar radiation, or rated power. R differs from CF in that it is affected negatively by temperature. As a result, it decreases during the hot months and increases during the winter. In contrast, the intensity of solar radiation has a positive impact on CF. As a result, it rises during months when solar radiation is intense with high temperatures, and vice versa [29, 30, 31, 32].

Tables 5 and 6 show a comparison of the PR and CF between the mono-Si PV system, the simulated PV system, and the CIGS PV system, respectively [29, 30]. These tables clearly show that the simulated and mono-Si PV systems are very close, whereas they differ significantly from CIGS PV system. Table 7 compares Iraq's PR and CF with those of other countries.

Table (5): PR comparison between actual and simulated systems.

| | Simulated PV system | Mono-Si PV system (actual system) [29] | CIGS PV system (actual system) [30] |
|----------------------|---------------------|--|-------------------------------------|
| Annual average of PR | 72% | 74.7% | 81.1% |
| Maximum PR (winter) | 76% | 82.7 | 84.11% |
| Minimum PR (summer) | 67% | 66.5% | 76.61% |

Table (6): CF comparison between actual and simulated systems.

| | Simulated PV system | Mono-Si PV system (actual system) [29] | CIGS PV system (actual system) [30] |
|----------------------|---------------------|--|-------------------------------------|
| Annual average of CF | 17.85% | 17.7% | 20.3% |
| Maximum CF (summer) | 21.7% | 20.85% | 25% |
| Minimum CF (winter) | 12.5% | 13.7% | 15.4% |

Table (7): PR and CF parameters comparison between Iraq and different countries.

| Country | PR | CF | Ref |
|------------|------------------------|------------------------|----------|
| Iraq | 66.5% - 82.7% | 13.7% - 20.85% | [30] |
| Egypt | 63% - 82% | 12.75% - 17.5% | [33] |
| Jordan | 87.5% (annual average) | 18.7% (annual average) | [34] |
| Oman | 82.3% (annual average) | 21.4% (annual average) | [35] |
| Algeria | 60.065 – 83.6% | 15.4% - 24.42% | [36] |
| India | 68% - 82% | 16% - 20% | [37, 38] |
| Mauritania | 63.6% - 73.6% | 11.6% - 20.5% | [39,40] |
| Brazil | 72.9% - 91.9% | 15.5% - 23.1% | [39] |

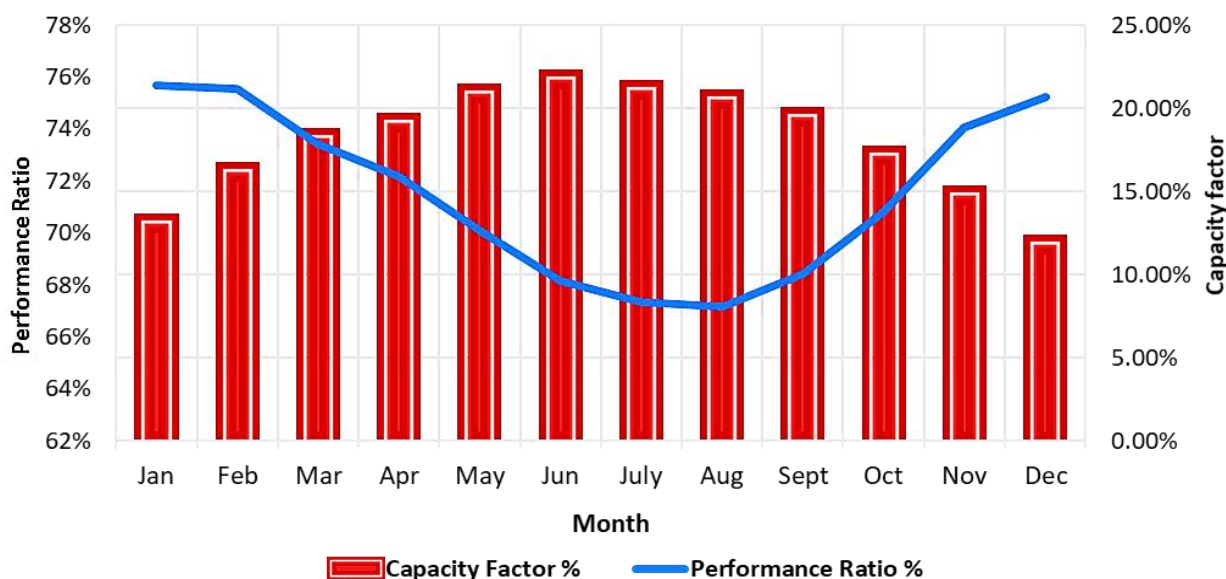

Figure (11): Performance ratio and capacity factor.

Verification of Helioscope accuracy

The accuracy of the Helioscope software is calculated by comparing it to an actual solar PV system with the same technical characteristics. This comparison was made using the comparison parameters: power output (if the both systems have the same rated power), PR, CF, energy yield, and overall losses.

The accuracy of the simulated solar PV system increases as it approaches the actual solar PV system. The actual PV system is a 5 kW grid-connected mono-Si mounted in Baghdad. Table 9 displays the comparison between Helioscope PV system and actual PV system (mono-Si PV system) [26].

Table (9): Comparison between Helioscope and mono-Si PV solar systems.

| Performance parameter | Actual PV system (mono-Si) [26] | Helioscope PV system | Error | Helioscope Accuracy ratio |
|-------------------------|---------------------------------|----------------------|------------------------|---------------------------|
| Energy output | 7891 kWh | 7819 kWh | -0.91% | 99.09% |
| CF | 17.75% | 17.85% | 0.85% | 99.15% |
| PR | 74.7% | 72% | -3.61% | 96.4% |
| AC Energy (final) yield | 4.5 kWh/kWp/day | 4.3 kWh/kWp/day | -4.44% | 95.6% |
| Average | | | -4.44% to 0.85% | 97.55% |

Conclusions

Helioscope software doesn't provide all performance parameters. Helioscope average accuracy is 97.55%. Helioscope software provides an annual average of PR, while the losses are for the hottest month only. Helioscope software provides comprehensive technical and electrical details. The annual energy production of the CIGS, mono-silicon, and Helioscope systems is 8,792 kWh, 7,891 kWh, and 7,819.3 kWh, respectively. Thus, the Helioscope is very close to a mono-silicon PV system but far from a CIGS PV system Annual average

overall losses for CIGS, mono-Si and, Helioscope PV systems are 19.9%, 24.5% and 29%, respectively.

PR and CF parameters for Iraq are excellent compared to many countries. CIGS PV solar system performance ratio is better than simulated and mono-Si PV systems because the temperature coefficient of CIGS PV modules is lower than that of silicon PV modules technology. The annual averages of PR and CF for CIGS, mono-Si and, Helioscope systems are 81.1% & 20.3%, 74.7% & 17.75%, and 72% & 17.85, respectively. CIGS PV solar modules are more suitable for the hot climates of Iraq than mono-Si technology. Ambient temperature and solar

radiation are the most influential weather factors on the performance of solar PV systems. Helioscope validation is - 4.44% to 0.85% or $\pm 2.45\%$ as average.

The authors propose:

1. Adding cooling technology to solar PV systems to improve their performance.
2. Use simulation tools before constructing the PV solar systems.

Disclosure Statement

- **Ethical Approval and Consent to Participate:** Not applicable
- **Consent of publication:** Authors give permission to the publisher to publish the work.
- **Availability of data and materials:** Data and materials are available from the corresponding author.
- **Author's contribution:** Study design and preparation: Alaa Najem. Data collection and analysis: Hiba Ali. Calculations and graphics: Alaa Najem and Basim Ibrahim. Interpretation and discussion of results: Alaa Najem, Basim Ibrahim, and Hiba Ali. All authors reviewed the results and approved the final version of the manuscript.
- **Funding:** Not applicable
- **Conflict of interest:** The authors declare no conflict of interest concerning of publication of this work.
- **Acknowledgements:** The authors acknowledge the support of Mustansiriyah University/College of Science in carrying out this investigation.

Open Access

This article is licensed under a Creative Commons Attribution 4.0 International License, which permits use, sharing, adaptation, distribution and reproduction in any medium or format, as long as you give appropriate credit to the original author(s) and the source provides a link to the Creative Commons license and indicates if changes were made. The images or other third-party material in this article are included in the article's Creative Commons license, unless indicated otherwise in a credit line to the material. If material is not included in the article's Creative Commons license and your intended use is not permitted by statutory regulation or exceeds the permitted use, you will need to obtain permission directly from the copyright holder. To view a copy of this license, visit <https://creativecommons.org/licenses/by-nc/4.0/>

References

- 1] Kasim NK, Hussain HH, Abed AN. Performance analysis of grid-connected CIGS PV solar system and comparison with PVsyst simulation program. *International Journal of Smart Grid*.2019;3(4):172-179. <https://www.ijsmartgrid.org/index.php/ijsmartgridnew>.
- 2] Abed AN, Hussain HH, Kasim NK. Efficiency and Performance Improvement Via Using Optical Reflectors of On-Grid CIGS PV Solar System. *Karbala International Journal of Modern Science*. 2020;6(1). doi:10.33640/2405-609X.1329
- 3] Kasim NK, Hussain HH, Abed AN. Enhancement of some electrical parameters of grid-connected PV solar system using planer concentrators. *Energy Sources, Part A: Recovery, Utilization, and Environmental Effects*. 2025;47(1):5393-5405. doi:10.1080/15567036.2021.1895374
- 4] Biswas S. Optimal investment policy in sharing and standalone economy for solar PV panel under operational cost. *Solar Energy*. 2023;264:112003. doi:10.1016/j.solener.2023.112003
- 5] Islam MdA, Ali MMN, Benitez IB, et al. A comprehensive evaluation of photovoltaic simulation software: A decision-making approach using Analytic Hierarchy Process and performance analysis. *Energy Strategy Reviews*. 2025;58:101663. doi:10.1016/j.esr.2025.101663
- 6] Dirlik EE, Gezegin C, Mohammadi SAD. Comparison of pvsyst, pvsol and homer simulation software results with real production data of solar power plants in different provinces of turkey. *Journal of Engineering Research and Applied Science*. 2023;12(2):2357-2364.
- 7] Renewable Energy Research Center-Kirkuk, Northern Technical University, Iraq, 36001 Kirkuk, Iraq, Husain MM. An experimental study on electricity generator emissions and their environmental impact in Kirkuk city. *AMME*. 2024;41:113-123. doi:10.7862/rm.2024.11
- 8] Ahmed WK, Abed TA, Salam AQ, Reza KS, MahdiY MT, ChaiChan MT. ENVIRONMENTAL IMPACT OF USING GENERATORS IN THE UNIVERSITY OF TECHNOLOGY IN BAGHDAD, IRAQ. *Journal of Thermal Engineering*. 2020;6(6):272-281. doi:10.18186/thermal.822496
- 9] Najem A, Wahab BI, Salman S. Estimating the Carbon Footprint of Civil Electrical Diesel Generators in Baghdad City. *IGJ*. Published online November 29, 2024:138-148. doi:10.46717/igj.57.2E.11ms-2024-11-20
- 10] Ramadan M, Alsarakji IH, Al-Khalil Q, Tobah M. Powering Agricultural Pumps by Solar Photovoltaic System – Case Study from Palestine. *An-Najah University Journal for Research - A*. 2024;38(2):85-90. doi:10.35552/aujr.a.38.2.2187
- 11] Hijazi R, Othman S, Shadeed S. GIS and Analytical Hierarchy Process (AHP)-Based Solar Energy Suitability Mapping in Palestine. *An-Najah University Journal for Research - A*. 2025;39(2):159-166. doi:10.35552/aujr.a.39.2.2361
- 12] Michael PO, Adetokun BB, Oghorada O. Performance Assessment of 407kW Photovoltaic Power System. In: *2022 IEEE Nigeria 4th International Conference on Disruptive Technologies for Sustainable Development (NIGERCON)*. IEEE; 2022:1-5. doi:10.1109/NIGERCON54645.2022.9803149
- 13] Umar N, Bora B, Banerjee C, Panwar B. Comparison of different PV power simulation softwares: case study on performance analysis of 1 MW grid-connected PV solar power plant. *International Journal of Engineering Science Invention (IJESI)*. 2018;7(7):11-24. www.ijesi.org.
- 14] Mahdi RO, Hacham W. Baghdad's Solar Power Potential: An Exploration Using PVsyst and HelioScope at Al-Khwarizmi College of Engineering. *alkej*. 2025;21(1):49-60. doi:10.22153/kej.2025.04.010
- 15] Hussein HA, Abed AN, Kasim NK. **Performance Comparison of Four Technologies of On-Grid PV Solar Systems under Baghdad Climate during February**. *IRAQI J ENVIRON SCI*. 2025;1(1):30-36. doi:10.71109/ijes.i1.11
- 16] Kumar NM, Das P, Krishna PR. Estimation of grid feed in electricity from roof integrated Si-amorph PV system based on orientation, tilt and available roof surface area. In: *2017 International Conference on Intelligent Computing*,

- Instrumentation and Control Technologies (ICICT)*. IEEE; 2017:588-596. doi:10.1109/ICICT1.2017.8342629
- 17] Abed AN, Kasim NK. Improve The Conversion Efficiency and Electrical Output of The Solar PV System by Developing and Implementing a Cooling System. *The Journal of Engineering Research*. 2025;20(2):161-171. doi:10.53540/tjer.vol20iss2pp161-171
 - 18] Das D, Saikia S, Saharia SJ, Mahapatra S. Performance analysis of MW-scale grid connected rooftop and ground-mounted solar power plants installed in Assam, India. *Energy for Sustainable Development*. 2023;76:101309. doi:10.1016/j.esd.2023.101309
 - 19] Kasim NK, Hussain HH, Abed AN. Boosting the energy output of an On-Grid solar PV system using a novel techniques. *JART*. 2023;21(6):1066-1074. doi:10.22201/icat.24486736e.2023.21.6.2036
 - 20] Kumar NM, Gupta RP, Mathew M, Jayakumar A, Singh NK. Performance, energy loss, and degradation prediction of roof-integrated crystalline solar PV system installed in Northern India. *Case Studies in Thermal Engineering*. 2019;13:100409. doi:10.1016/j.csite.2019.100409
 - 21] Abdallah R, Albatayneh A, Ali AS, Nasassrah A, Kashef M. Investigating the Impact of Water Cooling on the Performance of PV Modules in Palestine. *An-Najah University Journal for Research - A*. 2024;38(2):91-98. doi:10.35552/anjr.a.38.2.2195
 - 22] Kasim NK, Hussain HH, Abed AN. Increasing the Power Output of a PV Solar System by Using a Cooling-Reflector Assembly. *Proc eng technol innov*. 2022;22:40-49. doi:10.46604/peti.2022.9976
 - 23] Kasim NK, Hussain HH, Abed AN. Electrical Power Improvement of Grid-tied Photovoltaic Solar System. *Jordan Journal of Physics*. 2022;15(3):289-299. <https://doi.org/10.47011/15.3.7>
 - 24] Jamal J, Mansur I, Rasid A, Mulyadi M, Dihyah Marwan M, Marwan M. Evaluating the shading effect of photovoltaic panels to optimize the performance ratio of a solar power system. *Results in Engineering*. 2024;21:101878. doi:10.1016/j.rineng.2024.101878
 - 25] Hussain HH, Kasim NK, Abed AN. Estimation of Optimum Tilt Angles of Grid-Tied PV Solar System via PVsyst Program in Baghdad-Iraq. *Iraqi J Sci Technol*. 2021;12(2):52-61. <https://www.researchgate.net/publication/367338689>
 - 26] Najem A. YEARLY IMPROVEMENT OF GRID-CONNECTED SOLAR PV SYSTEM PARAMETERS BY PLANAR CONCENTRATORS. *Jou Eng Res*. 2023;19(2):140-151. doi:10.53540/tjer.vol19iss2pp140-151
 - 27] Kadi P, Kulkarni S, Nuchhi S, Ronad BF, Bagi S. Performance Evaluation of 3.3MWp Grid-Interfaced Solar PV Plant at Northern Karnataka Region of India Using PV Syst 7.4 Software. In: *2024 International Conference on Innovation and Novelty in Engineering and Technology (INNOVA)*. IEEE; 2024:1-6. doi:10.1109/INNOVA63080.2024.10847052
 - 28] Guittet DL, Freeman JM. *Validation of Photovoltaic Modeling Tool HelioScope Against Measured Data*. National Renewable Energy Laboratory (NREL), Golden, CO (United States); 2018.
 - 29] Abed AN, Kasim NK, Hussain HH. On-Grid Mono-Si PV Solar System Performance Evaluation in Baghdad. *IOP Conf Ser: Earth Environ Sci*. 2023;1223(1):012025. doi:10.1088/1755-1315/1223/1/012025
 - 30] Kasim NK, Hussain HH, Abed AN. Studying the performance of second-generation PV solar technology under Baghdad climate. *Research Journal in Advanced Sciences*. 2020;1(2):37-48.
 - 31] Zohir Torki, Mohamed Benhamida, Zakaria Haddad, Azzedine Nahoui, Aissa Chouder, Ibtissem Brahimi. Effects of Temperature and Solar Radiation on Photovoltaic Modules Performances Installed in Oued Keberit Power Plant, Algeria. *ARFMTS*. 2024;112(1):204-216. doi:10.37934/arfmts.112.1.204216
 - 32] Shaik F, Lingala SS, Veeraboina P. Effect of various parameters on the performance of solar PV power plant: a review and the experimental study. *Sustainable Energy res*. 2023;10(1):6. doi:10.1186/s40807-023-00076-x
 - 33] Besheer AH, Eldreny MA, Emara HM, Bahgat A. Photovoltaic Energy System Performance Investigation: Case Study of 5.1-kW Rooftop Grid Tie in Egypt. *J Energy Eng*. 2019;145(3):05019001. doi:10.1061/(ASCE)EY.1943-7897.0000605
 - 34] Hamzeh A, Hamid S, Al-Omari ZA, Sandouk A, Aldahim G. First year performance of a PV plant in Jordan compared to PV plants in the region. *International Journal of renewable energy research*. 2015;5(4):983-990.
 - 35] Yousif JH, Al-Balushi HA, Kazem HA, Chaichan MT. Analysis and forecasting of weather conditions in Oman for renewable energy applications. *Case Studies in Thermal Engineering*. 2019;13:100355. doi:10.1016/j.csite.2018.11.006
 - 36] Fezzani A, Guermoui M, Kouzou A, et al. Performances Analysis of Three Grid-Tied Large-Scale Solar PV Plants in Varied Climatic Conditions: A Case Study in Algeria. *Sustainability*. 2023;15(19):14282. doi:10.3390/su151914282
 - 37] Dobaria B, Pandya M, Aware M. Analytical assessment of 5.05 kWp grid tied photovoltaic plant performance on the system level in a composite climate of western India. *Energy*. 2016;111:47-51. doi:10.1016/j.energy.2016.05.082
 - 38] Padmavathi K, Daniel SA. Performance analysis of a 3MWp grid connected solar photovoltaic power plant in India. *Energy for Sustainable Development*. 2013;17(6):615-625. doi:10.1016/j.esd.2013.09.002
 - 39] De Lima LC, De Araújo Ferreira L, De Lima Morais FHB. Performance analysis of a grid connected photovoltaic system in northeastern Brazil. *Energy for Sustainable Development*. 2017;37:79-85. doi:10.1016/j.esd.2017.01.004
 - 40] Elhadji Sidi CEB, Ndiaye ML, El Bah M, Mbodji A, Ndiaye A, Ndiaye PA. Performance analysis of the first large-scale (15 MWp) grid-connected photovoltaic plant in Mauritania. *Energy Conversion and Management*. 2016;119:411-421. doi:10.1016/j.enconman.2016.04.070