

## The Safety Assessment of Trace Elements in Omega-3 Fish Oil Products Commonly Used for Infants in Jordan

Ala A. Alhusban<sup>1\*</sup>, Ghada I. Al-Azzeh<sup>1</sup>, Ola A. Tarawneh<sup>1</sup>, Haneen M. Abuzaid<sup>1</sup>, Samah A. Ata<sup>1</sup>

Type: Full Article. Received: 2<sup>nd</sup> Jan. 2025, Accepted: 21<sup>st</sup> Mar. 2025, Published: 1<sup>st</sup> Jun. 2026,

DOI: <https://doi.org/10.59049/2790-0231.11.2.2470>

**Abstract: MAX 250 words** Omega-3 fatty acids play an essential role in the growth and development of infants. Fish oil products containing omega-3s are OTC products and also prescribed repeatedly by pediatricians to enhance infants' immunity and growth and are easily accessible by parents. The main objective of this study was to evaluate the levels of 18 trace elements in seven fish oil products currently used for infants in Jordan. Two types of sample digestion methods were evaluated to detect the amounts of these metals in the fish oil products including: closed-microwave and open-wet methods, then the samples were analyzed by using a validated ICP-OES with LODs ranging from 0.05 ng/mL for Zn up to 320 ng/mL for Ni. The results showed a comparable level for elements detection using both digestion methods, which revealed that both digestion methods could be used interchangeably for preparing fish oil products. All detected elements (Al, Zn, Cu, and Cd) in tested products were within permitted levels according to the WHO criteria for the acceptable amounts of toxic elements and the ranges were 0.004 – 0.820, 26.02 – 0.229, 35.03 – 0.033, and 0.029 – 0.0001  $\mu\text{g}\cdot\text{mL}^{-1}$  for Al, Zn, Cu, and Cd respectively. The daily tolerated consumption limit established by the regulatory agencies was not exceeded by the levels of metals identified through fish oil products. The data obtained from this study show the importance of testing element levels in fish oil products as a routine procedure to assure products safety.

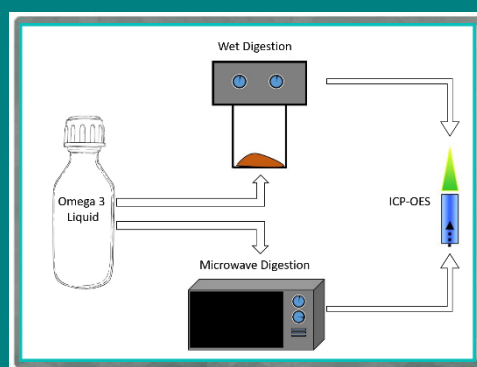

**Keywords:** infant, omega-3, fish oil products, open-wet digestion, closed-microwave digestion, toxic metals, safety assessment, ICP-OES.

### Introduction

Environmental pollutants, including potentially toxic metals exposure throughout the early life stages may shape the susceptibility of adulthood chronic diseases [1]. Infant exposure to toxic metals in the first 12 months of life may impair their development and growth for life [2]. The risk of long-time metal exposure is metal bioaccumulation in body organs, resulting in chronic toxic impacts that may be difficult to reverse [3]. In addition the, ingested metals' gastrointestinal tract absorption rate in infants and newborns is greater than in adults [4]. The absorption of ingested aluminum (Al) is 6 times higher in infants compared to adults which reaching up to 5% [5]. Likewise, the gastrointestinal absorption of ingested cadmium (Cd) is nearly 5–10% in adults but reaches up to 40% in infants [6]. Infants' exposure to toxic metals results in serious adverse events in comparison to adults [7, 8], leading to life-long defects in different cognitive abilities [9]. According to The International Agency for Research on Cancer (IARC), metals such Cd, As, Cr, Be and Ni have been classified as carcinogenic to humans (Group 1), unlike Al which has not been proven to be carcinogenic to humans yet, [10]. However, Al prolonged low-level exposure contributed to neurodegeneration and brain aging [11], particularly in infants [12].

Toxic metals that discharged into sea and river ecosystems may accumulate in marine organisms such fish as they feed on them. Humans are the most probably affected by toxic metal contamination through the food intake of aquatic foods and their

products such as fish oils [13]. Furthermore, toxic metals could be found in fish oils that produced from fish grown in industrially polluted waters [14]. The accumulation of toxic metals is mainly in fish liver rather than other organs [15]. Thus, determination of the toxic metal content in fish oil products that obtained from fish liver is very important. So far, little progress has been made in determining the levels of toxic metals in fish oil preparations [16, 17, 18, 19, 20]. However, the metal content determination in fish oil products used for infant were not been presented in the literature before.

Several techniques have been employed for the analysis of toxic elements in natural preparations. These techniques include atomic absorption spectrometry [21], energy-dispersive X-ray fluorescence [22], ion chromatography [23, 24], and inductively coupled plasma-mass spectrometry [25]. However, inductively coupled plasma-optical emission spectrometry (ICP-OES) has been used more frequently due to its efficiency, accuracy, reliability, and high sensitivity for multi-element determination at trace level [26, 27]. Two methods are usually used for preparation of the analyzed samples for the quantification of metals, [28, 29], these includes (1) the open-wet digestion procedure, which usually time-consuming and may lead to analyte loss, and (2) the closed-microwave digestion procedure which is more expensive but more suitable method for sample preparation due to its speed, efficiency, and save in analyte loss.

<sup>1</sup> Department of Pharmacy, Faculty of Pharmacy, Al-Zaytoonah University of Jordan, 130 Amman 11733, Jordan.

\*Corresponding author email: [ala.Alhusban@zu.ju.edu.jo](mailto:ala.Alhusban@zu.ju.edu.jo)

The aims of the present study are to compare two digestion methods (closed-microwave and open-wet) that will be used for sample preparation and then apply the methods to analyse several brands of infant pharmaceutical fish oil products (as a source of omega-3) commercially available in local pharmacies used by parents for infant growth and immunity enhancement in Jordan for possible toxic metals contamination.

## Materials and Methods

### Chemicals and reagents

HNO<sub>3</sub> (69%, w/v % trace metal concentration) was used for sample digestion (Fluka Analytical, France). Metal standard solutions (1000 ppm) of Al, Ag, As, Be, Bi, Cd, Cu, Cr, Co, Pb, Hg, Mo, Sb, Sn, Ni, Ag, V, and Zn used in all experiments were purchased from Merck. Five working standard solutions within the linear range for each element were prepared using the appropriate dilutions of metal stock solutions as described in the following table:

Element Name	Concentration (µg/10mL)
Aluminum (AL)	0.008
	0.01
	0.03
	0.05
	0.08
Zinc (Zn)	0.11
	0.2
	0.3
	0.4
	1.1
Copper (cu)	0.01
	0.022
	0.037
	0.075
	0.1
Nickle (Ni)	0.05
	0.72
	1
	0.25
	0.5
Mercury (Hg)	0.02
	0.035
	0.06
	0.12
	0.18
Lead (Pb)	0.03
	0.044
	0.14
	0.072
	0.3
Cadmium (cd)	0.001
	0.045
	0.064
	0.008
	0.01
Arsenic (As)	0.02
	0.003
	0.087
	0.16
	0.2
Antimony (Sb)	0.04
	0.013
	0.49
	0.14
	0.3
Beryllium (Be)	0.03
	0.0085
	0.043
	0.215
	0.3
Tin (Sn)	0.04
	0.01

Element Name	Concentration (µg/10mL)
Chromium (Cr)	0.53
	0.1
	0.4
	0.04
	0.1
Cobalt (Co)	0.17
	0.2
	0.4
	0.02
	0.015
Molybdenum (Mo)	0.054
	0.1
	0.2
	0.03
	0.015
Vanadium (V)	0.52
	0.12
	0.3
	0.003
	0.00129
Bismuth (Bi)	0.045
	0.0214
	0.03
	0.002
	0.0035
Silver (Ag)	0.0005
	0.008
	0.02
	0.003
	0.007
	0.037
	0.0229
	0.03

All plastic and glassware used were initially cleaned up with soap, washed thoroughly with tap water, and deionized water, and then soaked overnight in 10% (v/v) HNO<sub>3</sub>.

### Instrumentation

Shimadzu ICP-9000 inductively coupled plasma optical emission spectrometer (ICP-OES, Shimadzu, Japan) was used for the metal quantification. The instrument specifications and the optimum operating conditions for the use of the ICP-OES spectrometer were as follows: the RF power was 1400 W, the plasma flow rate, auxiliary gas flow rate, and the nebulizer gas flow rate were 12, 1.0, 1.0 L.min<sup>-1</sup> respectively, while the sample flow rate was 1.3 L.min<sup>-1</sup>, the spray chamber was double path scott type, the nebulizer was cross-flow, and the heater temperature was set at 30.6 °C. The method repeatability was calculated by analyzing each metal standard solution 5 times. Six standard solutions of each metal were examined, and the RSD values were calculated and values were ranged between 1.2% and 1.9%.

The accuracy of the analytical digestion procedures was tested by analysis of the certified reference material (CRM) GBW07605 tea sample) obtained from the National Analysis Centre for Reference Materials (China), using the same protocol of digestion procedures mentioned in section 2.4. Due to the limited amount of elements and unavailability of animal products' CRMs and some omega-3s were being added to products from plant origin, GBW07605 tea leaves CRM was used as it contains all the elements of interest.

### Sample collection

Seven different pharmaceutical fish oil products containing omega-3 fatty acids product brands in dosage form of syrup and drops intended for infant's use from 7 different manufacturers were collected randomly from different community pharmacies in Amman-Jordan in December 2022 as shown in Table (1) with various delivery batches. The original packaging of all the items

was retained. The collected samples were the only omega-3 fatty acids product brands registered by the JFDA in Jordan. All

products were purchased from community pharmacies in Amman-Jordan.

**Table (1):** Fish oil products symbols and descriptions used for analysis and their manufacturing country.

Product Symbol	Product Description	Manufacturing country	Expiry date
PB	Omega 3 syrup (each 1 ml of syrup contains 320 mg of fish oil 89.6 mg of EPA, 134.4 mg of DHA, and 60 mg of omega 6)	UK	3/2025
PS	Omega 3 syrup (each 1 ml of syrup contains 330 mg including 6.210 mg linoleic acid, 120 mg gamma linoleic acid, 88 mg omega 3)	Spain	1/2024
PJ	Omega 3 syrup (each 1 ml of syrup contains 300 mg of fish oil, 84 mg of EPA, 126 mg of DHA)	Jordan	6/2024
PV	Omega 3 syrup (each 1 ml of syrup contains 0.74 mg of honey, 60 mg of fish oil, 25 mg of DHA, and 5 mg of EPA)	Slovenia	4/2024
PI	Omega 3 syrup (each 1 ml of syrup contains 40 mg of bio DHA, 20 mg of krill oil)	Italy	10/2025
PT	Omega 3 syrup (each 1 ml of syrup contains 235 mg of fish oil, 70.5 total omega 3, 37.6 mg of EPA and 23.5 mg of DHA)	Turkey	11/2025
PA	Omega 3 drop (each 1 ml of syrup contains 167 mg omega 3 and 340 iu vitamin D)	USA	6/2023

### Sample preparation

Two digestion procedures commonly used (closed-microwave and open-wet) for sample preparation were evaluated. For the open-wet digestion method, a freshly made mixture of concentrated HNO<sub>3</sub> (10.0 mL) was added to a 50.0 mL Pyrex beaker along with 10.0 mL of syrup samples and 1.0 mL of oral drop samples taken from fish oil collected products and 1.0g from the CRM. The combination was then given approximately 15 minutes before covering it with a watch glass. then, the mixture was heated on a hot plate for about two hours (220-240 °C) until all of the samples were fully digested by obtaining clear solution. After allowing the resulting solution to cool, 30.0 mL of deionized water was added. The obtained samples were subsequently diluted with deionized water up to 50.0 mL.

For closed-microwave digestion, a 10.0 mL of freshly made mixture of concentrated HNO<sub>3</sub> (69%) was added to 50.0 mL microwave vessels with 10.0 mL of syrup samples and 1.0 mL of oral drops of the same fish oil products, and 1g from the CRM and samples were digested as follow: Ramp Time was 15 minutes, hold time was 15 minutes, and digestion temperature was 210 °C. After microwave digestion, the resulting solutions were diluted to 50.0 mL with deionized water.

The concentrations of the tested metals (n=3) were stated as the mean values of volume ± SD. Table (2) showed the method's LODs for each metal in the examined samples, as determined by the previous procedure. The amount of each analyzed sample was 0.01 L and was finally diluted to 0.050 L according to following formula:

Method's LOD for each metal = [instrument's LOD\* for each metal (mg.L<sup>-1</sup>) × 0.05 L] ÷ 0.01 L.

\*instrument's LOD for each metal (mg.L<sup>-1</sup>) were calculated based on the calibration curves

**Table (2):** The ICP-OES Method's LODs for each Metal.

Metal name	Method's Limit of Detection (LOD) (mg/L)
Aluminum (Al)	0.00700 mg/L
Zinc (Zn)	0.00005 mg/L
Copper (Cu)	0.00800 mg/L
Nickel (Ni)	0.32000 mg/L
Mercury (Hg)	0.00700 mg/L
Lead (Pb)	0.01300 mg/L
Cadmium (Cd)	0.00080 mg/L
Arsenic (As)	0.00200 mg/L
Nickle (Ni)	0.01500 mg/L
Antimony (Sb)	0.03500 mg/L
Beryllium (Be)	0.06000 mg/L
Tin (Sn)	0.05800 mg/L
Chromium (Cr)	0.00600 mg/L
Cobalt (Co)	0.00700 mg/L
Molybdenum (Mo)	0.05000 mg/L
Vanadium (V)	0.03000 mg/L
Bismuth (Bi)	0.02000 mg/L
Silver (Ag)	0.00700 mg/L

### Daily dosage determination of toxic metals

The estimated daily intake of metals by infants who were exposed to the pharmaceutical fish oil products is between the ages of 6 and 12 months having average weight of 10.0 kg was calculated using the following formula:

The daily metal intake (µg / day) in the analyzed fish oil product = metal content of 1 mL of the fish oil product (µg) × the daily amount that a medical expert advises (mL)

### Statistical analysis

Data (n=3) were presented as means ± standard deviation (SD). One-way ANOVA and Two-way ANOVA statistical analyses followed by Šidák's multiple comparisons test were employed to explore significant differences which was defined as \* (P < 0.05), \*\* (P < 0.01), \*\*\* (P < 0.001), \*\*\*\* (P < 0.0001). The software used was GraphPad Prism.

### Results and Discussion

#### Validation of Digestion Methods

A comparison and experimental evaluation between two approaches for sample preparation by digestion methods that are commonly applied in analysis of metals according to the certified reference material (CRM) (GBW07605) were carried out in this study. Seven fish oil products intended as food supplements for infants and children in Jordan were analyzed for 18 trace elements according to the acceptance criteria of toxic elements of WHO.

For the evaluation of the two above-mentioned digestion methods, analyses of tea certified reference material (GBW07605) samples (n=3) were conducted to quantify for the metal's contents and to estimate the percent recovery of each element. Table (3) presents elements' recovery percentage values following both digestion methods.

**Table (3):** Closed-microwave and open-wet digestion meth-ods accuracy assessments using Tea Certified Reference Material (GBW07605 tea sample).

Metal name	Recovery for closed-microwave digestion %	Recovery for open-wet digestion %
Al	98% ± 4.57	94% ± 4.08
Zn	98% ± 4.45	94% ± 4.38
Cu	97% ± 6.87	94% ± 5.84
Ni	99% ± 2.52	94% ± 4.33
Hg	92% ± 8.33	91% ± 5.45
Pb	101% ± 4.74	98% ± 4.04
Cd	97% ± 1.09	95% ± 4.62
As	100% ± 2.21	95% ± 3.19
Sb	97% ± 4.60	92% ± 4.87
Be	97% ± 6.06	96% ± 13.80
Cr	98% ± 7.25	97% ± 3.95
Co	97% ± 5.02	95% ± 10.11
Mo	100% ± 4.47	103% ± 4.35
V	98% ± 4.78	98% ± 7.38
Bi	98% ± 4.05	95% ± 7.38
Ag	98% ± 8.82	93% ± 5.88

As demonstrated in Table (3), the detected values of 16 different elements were measured. The recovery values for elements were calculated for both closed-microwave and open-wet digestion methods respectively according to the following equation:

Recovery % = Determined concentration for each element / certified concentration for the element X 100.

The detected values for each element in the two digestion methods showed high recovery values compared to CRM reference values (> 93%) except for mercury with a recovery

**Table (4):** Concentration levels of Al, Zn, Cu, and Cd ( $\mu\text{g}\cdot\text{mL}^{-1}$ ) in omega 3 fish oil products and daily intake of infants and children (body weight 10 kg) ( $\mu\text{g}/\text{day}$ ) using closed-microwave digestion sample preparation and ICP-OES

Product Description	Aluminum (Al) ( $\mu\text{g}\cdot\text{mL}^{-1}$ )	(Al) daily intake ( $\mu\text{g}/\text{day}$ )	Zinc (Zn) ( $\mu\text{g}\cdot\text{mL}^{-1}$ )	(Zn) daily intake ( $\mu\text{g}/\text{day}$ )	Copper (Cu) ( $\mu\text{g}\cdot\text{mL}^{-1}$ )	(Cu) daily intake ( $\mu\text{g}/\text{day}$ )	Cadmium (Cd) ( $\mu\text{g}\cdot\text{mL}^{-1}$ )	(Cd) daily intake ( $\mu\text{g}/\text{day}$ )
PB	0.00347 ± 0.00030	0.00850	< LOD	< LOD	0.03260 ± 0.00090	0.08150	< LOD	< LOD
PS	0.08170 ± 0.00009	0.40850	2.81600 ± 0.03600	14.08000	5.04200 ± 0.03600	25.21000	< LOD	< LOD
PJ	0.02083 ± 0.00017	0.10415	0.22900 ± 0.00285	1.14500	2.96900 ± 0.01000	14.84700	0.02970 ± 0.00100	0.14850
PV	0.06370 ± 0.00123	0.31850	0.91690 ± 0.01180	4.58300	3.98397 ± 0.05020	19.91500	< LOD	< LOD
PI	< LOD	< LOD	0.62570 ± 0.00700	3.12850	0.11620 ± 0.00340	0.58100	0.00010 ± 0.00001	0.00050
PT	0.06020 ± 0.00050	0.30100	26.00790 ± 0.06100	130.04000	35.03057 ± 0.05150	17.51500	< LOD	< LOD
PA	0.05437 ± 0.00120	0.05430	15.98700 ± 0.14900	15.98700	28.00387 ± 0.21750	28.00300	< LOD	< LOD

**Table 5:** Concentration levels of Al, Zn, Cu, and Cd ( $\mu\text{g}\cdot\text{mL}^{-1}$ ) in omega 3 fish oil products and daily intake of infants and children (body weight 10 kg) ( $\mu\text{g}/\text{day}$ ) using closed-microwave digestion sample preparation and ICP-OES.

Product Description	Aluminum (Al) ( $\mu\text{g}\cdot\text{mL}^{-1}$ )	(Al) daily intake ( $\mu\text{g}/\text{day}$ )	Zinc (Zn) ( $\mu\text{g}\cdot\text{mL}^{-1}$ )	(Zn) daily intake ( $\mu\text{g}/\text{day}$ )	Copper (Cu) ( $\mu\text{g}\cdot\text{mL}^{-1}$ )	(Cu) daily intake ( $\mu\text{g}/\text{day}$ )	Cadmium (Cd) ( $\mu\text{g}\cdot\text{mL}^{-1}$ )	(Cd) daily intake ( $\mu\text{g}/\text{day}$ )
PB	0.00383 ± 0.00025	0.00950	< LOD	< LOD	0.03930 ± 0.00060	0.09800	< LOD	< LOD
PS	0.08570 ± 0.00660	0.42900	2.84083 ± 0.10015	14.20000	4.81420 ± 0.14600	24.07000	< LOD	< LOD
PJ	0.02920 ± 0.00360	0.14600	0.24700 ± 0.03540	1.23500	0.29200 ± 0.08390	1.46000	0.00360 ± 0.00045	0.01800
PV	0.06740 ± 0.00743	0.33700	0.84507 ± 0.02907	4.22500	3.71480 ± 0.17700	18.57500	< LOD	< LOD
PI	< LOD	< LOD	0.64137 ± 0.04900	3.20500	0.13290 ± 0.01230	6.64500	0.00010	0.00050
PT	0.05470 ± 0.00315	0.27350	23.35000 ± 0.16000	116.75000	31.22700 ± 0.28000	156.10000	< LOD	< LOD
PA	0.04930 ± 0.00317	0.04930	14.09000 ± 0.75000	14.09000	24.45800 ± 0.59900	24.45800	< LOD	< LOD

### Metals levels in the analyzed fish oil products

Another significant aspect of this investigation is to determine the levels of elements in the seven fish oil products (from different manufacturing origins) and to evaluate their levels for acceptance according to WHO criteria of toxic elements.

Table 5 list the concentrations of detected elements (Al, Zn, Cu, and Cd) from the analyzed samples in addition to their calculated daily requirements from medicinal omega-3 fish oil products. The presented results demonstrated that only four elements (Al, Zn, Cu, and Cd) were detected in the investigated omega-3 fish oil products. On the other hand, other metals investigated including Ni, Hg, Pb, As, Ni, Sb, Be, Sn, Cr, Co, Mo, V, Bi, and Ag were below the method's LODs.

Sample digestion is the fundamental experiment to extract the metals from the formula where the metal may establish physical or chemical bonds with the components of the formula (whether liquid or solid formulas). Therefore, sample digestion is crucial step in the analytical processes used to determine trace elements due to its warrants reliable and accurate results. The two digestion techniques used for evaluation are namely: the open-wet digestion method; which offers the merits of low

value of > 91 %. This further validates our verified analysis technique using ICP-OES and supports its use in future studies [30, 31].

Analysis of the seven different fish oil products as a source of omega-3 was performed to detect 18 elements as mentioned in Table 5. However, only three elements Al, Zn, and Cu were detected in all analyzed samples from both digestion methods and were used for the validation purpose. On the other hand, traces of Cd were detected in only two fish oil products and thus was excluded from validation.

equipment cost [32], easy automated operation, efficient and straightforward control of all parameters (time, temperature, and the introduction of chemical reagents) [33]. The second digestion method is the closed-microwave digestion method which provides reduction in the loss of volatile elements like Hg and Pb in noticeable shorter time period upon conducting the experiment [34].

For the assessment of the two digestion methods, analyses of tea certified reference material (GBW07605) samples (n=3) were quantified for the elements contents and the percent recovery of each element was estimated as presented in Table 3. All detected values of each element between the two methods were compared using two-way ANOVA followed by Šidák's multiple comparisons test and results were presented in Figure (1)\* (P < 0.05), \*\* (P < 0.01), \*\*\* (P < 0.001), \*\*\*\* (P < 0.0001). Although, closed-microwave digestion showed closer recovery values to the reference values in comparison to the open-wet digestion method, there were no significant differences between the closed-microwave and open-wet digestion methods. Consequently, this finding further supports the usage of both digestion methods for the analysis of samples [35].

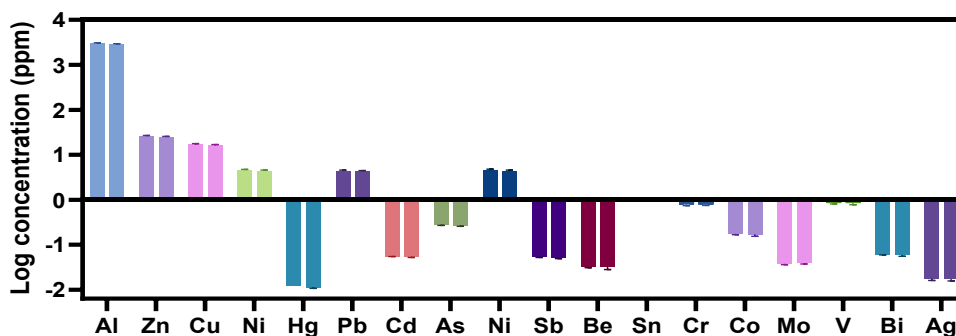

**Figure (1):** Summary of concentration values (ppm) of 18 elements analyzed by ICP-OES spectrometer of certified reference material GBW07605 tea sample. Samples were analyzed after using both the closed-microwave (first column) and the open-wet (second column) digestion methods. Data points represent log concentration mean  $\pm$  SD (n = 3). Considering the significant statistical significance of  $p \leq 0.05$ ; no significant differences were detected between the two used digestion methods for the same detected element.

All seven fish oil samples were analyzed using both methods. Analysis of fish oil samples (n= 3) using the two digestion methods was carried out with the same procedure used

with the certified reference material (GBW07605). Figure (2) showed the comparison of metal contents ( $\mu\text{g/mL}$ ) for Al, Zn, and Cu respectively.

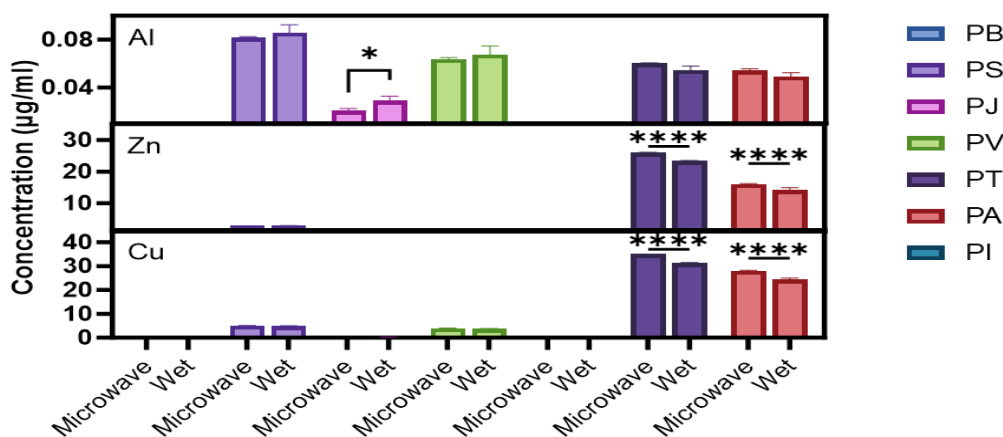

**Figure (2):** Concentrations ( $\mu\text{g/mL}$ ) of Al, Zn, and Cu in seven natural oil products from different origins. All samples were analyzed by ICP-OES spectrometer following their digestion with both the closed-microwave and the open-wet methods. Data points represent concentration mean  $\pm$  SD (n = 3). Significant differences between the closed-microwave and open-wet digestion methods for the same detected element are expressed as \* $P < 0.05$  and \*\*\*\* $P < 0.0001$ .

The levels of the detected elements varied between different products. This variation was attributed to the products' type but not the digestion method used to prepare the samples. Indeed, detected levels of Zn and Cu were similar in five different tested products (PB, PS, PJ, and PV) compared to the same samples prepared with different digestion method (Figure (2)). However, there was a significant difference between detected levels of Zn and Cu in products PT and PA when prepared with different digestion methods ( $p \leq 0.0001$ ). The closed-microwave digestion method shows significantly higher detected levels for Zn and Cu (Figure (2)). On the other hand, the detected Al level prepared by the open-wet digestion method showed a significantly higher value compared to the sample prepared by the closed-microwave method ( $p \leq 0.05$ ). These findings confirm that the tested digestion methods were similar. Furthermore, both closed-microwave and open-wet digestion methods can offer comparable and reliable results when combined with a validated analysis technique.

### Fish oil products elements levels

A comparison between the detected metals levels (Al, Zn, Cu, and Cd) and their permitted levels set by WHO was performed to report the analyzed products' safety usage. According to the International Program on Chemical Safety (IPCS) in 2009 and WHO (2007), the maximum recommended

tolerable limits of Zn, Cu, and Cd are  $99.4 \mu\text{g.g}^{-1}$ ,  $73.3 \mu\text{g.g}^{-1}$  and  $0.2 \mu\text{g.g}^{-1}$  respectively [36, 37]. The provisional maximum tolerable daily intake (PMTDI) for Zn of 0.3-1.0 mg/kg bw/d is based on clinical investigations in which up to 600 mg of zinc sulfate (equal to 200 mg elemental zinc) has been given daily in divided doses for several months for infant [38]. The present results showed that Zn values were found to vary between  $0.229 \mu\text{g.mL}^{-1}$  and  $26.0079 \mu\text{g.mL}^{-1}$ . The lowest Zn concentration found was  $0.229 \pm 0.00285 \mu\text{g.mL}^{-1}$  in product PJ, the highest Zn content which was  $26.0079 \pm 0.061 \mu\text{g.mL}^{-1}$  was in product PT (Table 5). The maximum acceptable limit is set at  $99.4 \mu\text{g.g}^{-1}$ , accordingly, all oil products were found to have less Zn content than what is permitted by the WHO for omega-3 products [36] and within the allowed range for daily intake. On the other hand, Cu levels in food that are considered to satisfy nutritional needs are 2-3 mg/day for adults and 0.5-0.7 mg/day for newborns [38]. In all pharmacological omega-3 products, Cu was found at concentrations between  $0.0326 \pm 0.09$  and  $35.03057 \pm 5.15 \mu\text{g.mL}^{-1}$ ; the maximum level of Cu was found in product PT and the lowest measured Cu content was found in product PB. Regarding to the permitted level of Cu by the WHO for omega-3 products [36], the levels of Cu in tested oil products were within the allowed range. Table 5 showed that Cd was not found in all of the analyzed samples, but was only found in product PJ with values of  $0.0036 \pm 0.00045 (\mu\text{g.mL}^{-1})$ . The WHO maximum

recommended tolerable limit of Cd in omega-3 products is defined at  $0.30 \text{ mg.kg}^{-1}$  [39], and thus the value in product PJ is under the permissible limit. For Al, no permissible limit on medicines and related products has been established or recommended by WHO till now. The Committee proposed that the modified Provisional Tolerable Weekly Intake (PTWI) for Al compounds of  $2 \text{ mg/kg}$  body weight as Al from all sources must be compatible with rules for food additives containing Al included in the Codex General Standard for Food Additives [38]. This indicates that  $143 \text{ }\mu\text{g/kg}$  of body weight has been established as the tolerated daily consumption. Assuming a dosage for a baby aged between 6 and 12 months with an average weight of  $10 \text{ kg}$ , as represented in Table 5, the maximum intake of Al must not exceed the PTWI of  $1.43 \text{ mg}$  per day.

According to the study results, the four detected elements are considered to exist below the permissible limits in the analyzed fish oil products from different sources of origin (Table 5) prepared by both digestion methods and can be considered safe products to use in infants. However, this finding must be interpreted with caution and not generalized for all populations in Jordan. Although the prevalence of undernourishment in Jordan's population was 6% in 2010, this percentage has been

increasing in the following decade to record 17% of the population in 2020 [40]. For elemental nutrients like Zn and Cu, adding a fish oil product to an infant's diet containing these nutrients can be beneficial for malnourished and poorly nourished infants. On the other hand, adding a fish oil product to a well-nourished infant can unpredictably increase the levels of such elements when combined with rich food sources, such as red meat and liver [41]. However, Al and Cd considered as toxic elements and not nutrients when exceeding their permitted levels. Thus, any factor that might increase their levels in fish oil products will have adverse effects on infant health. These factors may originate from the elevated levels of elements in water systems due to industrial and agricultural activities, surface soil erosion, as well as water pollution. Moreover, the distribution of such elements can differ from water source to another. It was reported that the Atlantic Ocean is known to contain more Al than the Pacific Ocean, Also the amount of Al in seawater can vary between approximately 0.013 and 5 ppb. [42, 43, 44, 45], this might also explain the significant differences in elements found in different fish oil products from different manufacturing origins. Figure (3) showed significant differences in the same element between different oil products ( $p < 0.0001$ ).

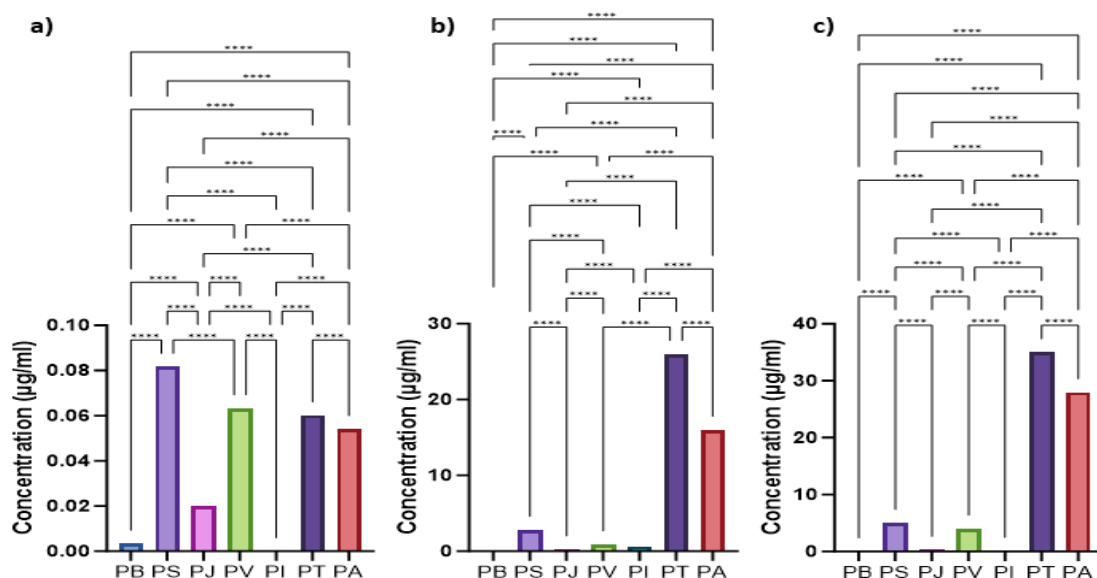

**Figure (3):** Comparable concentration values ( $\mu\text{g/mL}$ ) of Al (a), Zn (b), and Cu (c) detected from seven natural oil products from different origins. All samples were analyzed by ICP-OES spectrometer following their digestion with the closed-microwave method. Data points represent concentration mean  $\pm$  SD ( $n = 3$ ). Significant differences of the same detected element between the different fish oil products are expressed as \*\*\*\* $P < 0.0001$ .

Product PS has a significantly higher amount of detected Al than product PB ( $P < 0.0001$ ) although the amount of omega-3 is similar. In contrast, the highest average levels of Zn and Cu were detected in product PT with  $\sim 26 \text{ }\mu\text{g/ml}$  and  $\sim 35 \text{ }\mu\text{g/ml}$  respectively, these values were significantly higher than all other tested products that were detected down to  $\sim 0.2 \text{ }\mu\text{g/ml}$  and  $\sim 0.03 \text{ }\mu\text{g/ml}$  for Zn and Cu respectively ( $p < 0.0001$ ).

According to previous results, the marine source plays an essential role in affecting the levels of elements in fish oil products. This also confirms the importance of elements testing in fish oil products by manufacturing companies as well as identifying a safe marine source for their oil products before supplying the markets. However, this will be hard to implement by companies unless enforce obligation to pharmacopeia. Actually, the acceptance criteria of natural products by pharmacopeia does not require detecting the levels of all elements nor their seawater source. Moreover, using these fish oil products as an OTC and the existence of unpredicted factors

that affect the levels of elements from different water sources will have more impact on an infant's health especially when combined with pharmacists' practice of safely using alternatives.

## Conclusion

In this study, potential toxic metal contaminations in seven infants' pharmaceutical natural omega-3 fish oil commercial products were investigated in the Jordanian market. These products are OTC products and frequently utilized for medical treatment and have recently been prescribed by healthcare professionals to enhance mental development, growth, and immunity in infants and children. Despite the fact that, this study confirmed that accepted levels of Al, Zn, and Cu as per WHO recommendations for medicinal natural omega-3 fish oil preparations, it did substantiate the importance of testing element levels in fish oil products by manufacturing companies as a routine procedure. This is related to the significant differences detected for the same elements between oil products

from different manufacturing countries (mostly from different water sources). The recent findings showed that the baby pharmaceutical natural omega-3 oil products can be used carefully and not on frequent use for a very long time for the safety of the newborns. Consequently, the awareness of the potential future toxicity of the products should be generated to prevent their adverse effect on infants' health in case metal pollution of the marine environment occurs.

## Disclosure Statement

- **Ethics approval and consent to participate:** Ethical approval is not applicable for this article.
- **Consent for publication:** Not applicable
- **Availability of data and materials:** The raw data required to reproduce these findings are available in the body and illustrations of this manuscript.
- **Author's contribution:** Author's contribution should be added, for example.
- The authors confirm contribution to the paper as follows: study conception and design: Smith, J2, theoretical calculations and modeling: Smith, J3; data analysis and validation, Smith, J2, Smith, J3. draft manuscript preparation: Smith, J3, Smith, J4. All authors reviewed the results and approved the final version of the manuscript.
- **Funding:** This work received financial support from the Deanship of Scientific Research and Innovation at Al-Zaytoonah University of Jordan [grants no. 2022-2023/17/49].
- **Conflicts of interest:** The authors declare that there is no conflict of interest regarding the publication of this article
- **Acknowledgements:** The authors are grateful to the Deanship of Scientific Research and Innovation at Al-Zaytoonah University of Jordan [grants no. 2022-2023/17/49] for the support received.

## Open Access

This article is licensed under a Creative Commons Attribution 4.0 International License, which permits use, sharing, adaptation, distribution and reproduction in any medium or format, as long as you give appropriate credit to the original author(s) and the source, provide a link to the Creative Commons licence, and indicate if changes were made. The images or other third-party material in this article are included in the article's Creative Commons licence, unless indicated otherwise in a credit line to the material. If material is not included in the article's Creative Commons licence and your intended use is not permitted by statutory regulation or exceeds the permitted use, you will need to obtain permission directly from the copyright holder. To view a copy of this licence, visit <https://creativecommons.org/licenses/by-nc/4.0/>

## References

- 1] Abu Lawi D, Blasi R, AlNimer M, Ghazzaw H. Assessment of dietary consumption in a group of pregnant women at their second and third trimesters in Amman. *Palestinian Medical and Pharmaceutical Journal*. 2023;8(1):3.
- 2] Lin Y-C, Chang W-H, Li T-C, Iwata O, Chen H-L. Health risk of infants exposed to lead and mercury through breastfeeding. *Exposure and Health*. 2023;15(1):255-67.
- 3] Melø R, Gellein K, Evje L, Syversen T. Minerals and trace elements in commercial infant food. *Food and chemical toxicology*. 2008;46(10):3339-42.
- 4] Sipahi H, Eken A, Aydın A, Şahin G, Baydar T. Safety assessment of essential and toxic metals in infant formulas. *Turkish Journal of Pediatrics*. 2014;56(4).
- 5] Zatta P, Alfrey AC. *Aluminium Toxicity in Infants' Health and Disease*: World Scientific; 1997.
- 6] Crews HM, Owen LM, Langford N, Fairweather-Tait SJ, Fox TE, Hubbard L, et al. Use of the stable isotope <sup>106</sup>Cd for studying dietary cadmium absorption in humans. *Toxicology letters*. 2000;112:201-7.
- 7] Chao H-H, Guo C-H, Huang C-B, Chen P-C, Li H-C, Hsiung D-Y, et al. Arsenic, cadmium, lead, and aluminium concentrations in human milk at early stages of lactation. *Pediatrics & Neonatology*. 2014;55(2):127-34.
- 8] Ata S, Jarrar W, Alhusban AA, Altarawneh M. Assessment of Knowledge and Attitude Regarding Lead Poisoning Among Pharmacists in Jordan. *Polish Journal of Environmental Studies*. 2024;33(3).
- 9] Neethu KV, Praved PH, Xavier N, Sankar ND, Antony H, Nandan SB, et al. Bioaccumulation of heavy metals in seafood resources from the southwest coast of India: human health risk assessment and importance of seafood security. *Toxicology and Environmental Health Sciences*. 2024:1-15.
- 10] IARC. International Agency for Research on Cancer. Classified by the IARC Monographs. <http://monographs.iarc.fr/ENG/Classification/>: IARC; 2018 [
- 11] Bondy SC. Prolonged exposure to low levels of aluminum leads to changes associated with brain aging and neurodegeneration. *Toxicology*. 2014;315:1-7.
- 12] Dórea JG. Exposure to mercury and aluminum in early life: developmental vulnerability as a modifying factor in neurologic and immunologic effects. *International journal of environmental research and public health*. 2015;12(2):1295-313.
- 13] Kumari P, Chowdhury A, Maiti SK. Assessment of heavy metal in the water, sediment, and two edible fish species of Jamshedpur Urban Agglomeration, India with special emphasis on human health risk. *Human and Ecological Risk Assessment: An International Journal*. 2018;24(6):1477-500.
- 14] Zohra BS, Habib A. Assessment of heavy metal contamination levels and toxicity in sediments and fishes from the Mediterranean Sea (southern coast of Sfax, Tunisia). *Environmental science and pollution research*. 2016;23:13954-63.
- 15] Tepe Y, Türkmen M, Türkmen A. Assessment of heavy metals in two commercial fish species of four Turkish seas. *Environmental monitoring and assessment*. 2008;146:277-84.
- 16] Güzelsoy N, İzgi B. Optimization of analytical parameters for determination of (As, Hg, Cd and Pb) in fish oil supplements. *Journal of Food and Feed Science-Technology*. 2015.
- 17] John MTE, Rebry MRM, Yan K, Rice B, Rowe W. Measurement of environmental contaminants in a globally—representative sample of fish oil supplements. *White Pap Nutrasource Diagnostics Inc*. 2013:1-33.
- 18] Opperman M, Benade AS, Marais DW. Analysis of omega-3 fatty acid content of South African fish oil supplements: cardiovascular topics. *Cardiovascular Journal of Africa*. 2011;22(6):324-9.
- 19] Ozyurt G, Ekmen D, Durmuş M, Ucar Y. Assessment of the safety of dietary fish oil supplements in terms of content and quality. *Environmental Science and Pollution Research*. 2022;29(17):25006-19.

- 20] Rusu N, Meghea A. Bioaccumulation of toxic metals in fish oils capsules. *ecosystems*. 2015;77:131-40.
- 21] Massadeh AM, Alhusban AA. A developing method for preconcentration and determination of Pb, Cd, Al and As in different herbal pharmaceutical dosage forms using chelex-100. *Chemical Papers*. 2021;75:3563-73.
- 22] Reboredo F, Barbosa A, Silva M, Carvalho M, Santos J, Pessoa M, et al. Mineral content of food supplements of plant origin, by energy dispersive x-ray fluorescence: A risk assessment. *Exposure and Health*. 2020;12:917-27.
- 23] Jaber M, Hashemi P, Rahimi A. Reversed Phase Dispersive Liquid-Liquid Microextraction for Sensitive Ion Chromatographic Determination of Metal Cations in Sesame Oil. 2023.
- 24] Alhusban AA, Ata SA. Simple HPLC method for rapid quantification of nicotine content in e-cigarettes liquids. *Acta Chromatographica*. 2021;33(3):302-7.
- 25] Zavala M, Becker GL, Lenth R, Wels B, Kahler J, Schueller M, et al. Private well water arsenic exposures and lung function among rural lowans: a cross-sectional pilot study. *Toxicology and Environmental Health Sciences*. 2023;15(4):325-33.
- 26] Shrestha AK, Samarakoon T, Fujino T, Hagimori M. Detection of Zn<sup>2+</sup> ions using a high-affinity low-molecular-weight fluorescence probe in two freshwater organisms. *Toxicology and Environmental Health Sciences*. 2023;15(2):145-55.
- 27] Alkilany AM, Mahmoud NN, Hashemi F, Hajipour MJ, Farvadi F, Mahmoudi M. Misinterpretation in nanotoxicology: a personal perspective. *Chemical research in toxicology*. 2016;29(6):943-8.
- 28] Okati N, Shahriari Moghadam M, Einollahipeer F. Mercury, arsenic and selenium concentrations in marine fish species from the Oman Sea, Iran, and health risk assessment. *Toxicology and Environmental Health Sciences*. 2021;13:25-36.
- 29] Ayodeji OJ, Ikem A, Wetzell J, Awoyemi OM, Garth J. Sex-specific and inter-species differences in the accumulation and distribution profile of metal (loid) s in crayfish specimens. *Toxicology and Environmental Health Sciences*. 2021;13(2):143-52.
- 30] Alhusban AA, Ata SA, Hamadneh LA, Tarawneh OA, Abuzaid H, Albustanji S, et al. Toxic Metals Transfer from Heating Coils to e-liquids: Safety Assessment of Popular e-cigarettes in Jordan. *Jordan Journal of Pharmaceutical Sciences*. 2023;16(2):391-401.
- 31] Keshavarzi B, Moore F, Estahbanati NA. Soil trace elements contamination in the vicinity of Khatoon Abad copper smelter, Kerman province, Iran. *Toxicology and Environmental Health Sciences*. 2015;7:195-204.
- 32] Somer G, ÜNLÜ AN. The effect of acid digestion on the recoveries of trace elements: recommended policies for the elimination of losses. *Turkish Journal of Chemistry*. 2006;30(6):745-53.
- 33] Uddin A, Khalid RS, Alaama M, Abdulkader AM, Kasmuri A, Abbas S. Comparative study of three digestion methods for elemental analysis in traditional medicine products using atomic absorption spectrometry. *Journal of analytical science and technology*. 2016;7(1):1-7.
- 34] Alsehli BR. Evaluation and Comparison between a Conventional Acid Digestion Method and a Microwave Digestion System for Heavy Metals Determination in Mentha Samples by ICP-MS. *Egyptian Journal of Chemistry*. 2021;64(2):869-81.
- 35] Egrinya Eneji A, Yamamoto S, Wen G, Inanaga S, Honna T. A comparative evaluation of wet digestion and dry ashing methods for the determination of some major and minor nutrients in composted manure. *Toxicological & Environmental Chemistry*. 2005;87(2):147-58.
- 36] Organization WH. WHO guidelines for assessing quality of herbal medicines with reference to contaminants and residues: World Health Organization; 2007.
- 37] Shawahna R, Zyoud A, Amireh A, Hussien M, Daraghmah R, Nasser D, et al. Zinc concentrations in breast milk samples obtained from Palestinian lactating women: A cross-sectional study of signs of deficiency and dietary consumption of zinc sources. *Palestinian Medical and Pharmaceutical Journal (Pal Med Pharm J)*. 2024;10(1):None-None.
- 38] Joint F, Additives WECof, Organization WH. Safety evaluation of certain contaminants in food: prepared by the Seventy-second meeting of the Joint FAO/WHO Expert Committee on Food Additives (JECFA): World Health Organization; 2011.
- 39] Solimene U, Alkofahi A, Allemann C, Amigoni M, Aspan R, Azimova S, et al. WHO guidelines for assessing quality of herbal medicines with reference to contaminants and residues. 2007.
- 40] Amir-ud-Din R, Fawad S, Naz L, Zafar S, Kumar R, Pongpanich S. Nutritional inequalities among under-five children: a geospatial analysis of hotspots and cold spots in 73 low-and middle-income countries. *International Journal for Equity in Health*. 2022;21(1):135.
- 41] Krebs NF. Food choices to meet nutritional needs of breast-fed infants and toddlers on mixed diets. *The Journal of nutrition*. 2007;137(2):511S-7S.
- 42] Wu T, Li X, Yang T, Sun X, Mielke HW, Cai Y, et al. Multi-elements in source water (drinking and surface water) within five cities from the semi-arid and arid region, NW China: Occurrence, spatial distribution and risk assessment. *International Journal of Environmental Research and Public Health*. 2017;14(10):1168.
- 43] Council NR, Committee SDW. The contribution of drinking water to mineral nutrition in humans. *Drinking Water and Health Volume 3: National Academies Press (US)*; 1980.
- 44] Astatkie H, Ambelu A, Beyene EM. Sources and level of heavy metal contamination in the water of Awetu watershed streams, southwestern Ethiopia. *Heliyon*. 2021;7(3).
- 45] Moran S, Moore R. The potential source of dissolved aluminum from resuspended sediments to the North Atlantic Deep Water. *Geochimica et Cosmochimica Acta*. 1991;55(10):2745-51.